



AVTECH ELECTROSYSTEMS LTD.

NANOSECOND WAVEFORM ELECTRONICS  
SINCE 1975

P.O. BOX 265  
OGDENSBURG, NY  
U.S.A. 13669-0265  
TEL: (315) 472-5270  
FAX: (613) 226-2802

TEL: 1-800-265-6681  
FAX: 1-800-561-1970

e-mail: [info@avtechpulse.com](mailto:info@avtechpulse.com)  
<http://www.avtechpulse.com/>

BOX 5120, LCD MERIVALE  
OTTAWA, ONTARIO  
CANADA K2C 3H4  
TEL: (613) 226-5772  
FAX: (613) 226-2802

## INSTRUCTIONS

MODEL AVO-8C1-B-P

0 TO +40 V, 0 TO +200 AMP  
LASER DIODE DRIVER  
WITH IEEE 488.2 AND RS-232 CONTROL

SERIAL NUMBER: \_\_\_\_\_

### WARRANTY

Avtech Electrosystems Ltd. warrants products of its manufacture to be free from defects in material and workmanship under conditions of normal use. If, within one year after delivery to the original owner, and after prepaid return by the original owner, this Avtech product is found to be defective, Avtech shall at its option repair or replace said defective item. This warranty does not apply to units which have been disassembled, modified or subjected to conditions exceeding the applicable specifications or ratings. This warranty is the extent of the obligation assumed by Avtech with respect to this product and no other warranty or guarantee is either expressed or implied.

### TECHNICAL SUPPORT

Phone: 613-226-5772 or 1-800-265-6681

Fax: 613-226-2802 or 1-800-561-1970

E-mail: [info@avtechpulse.com](mailto:info@avtechpulse.com)

World Wide Web: <http://www.avtechpulse.com>

## TABLE OF CONTENTS

<b>WARRANTY.....</b>	<b>2</b>
<b>TECHNICAL SUPPORT.....</b>	<b>2</b>
<b>TABLE OF CONTENTS.....</b>	<b>3</b>
<b>INTRODUCTION.....</b>	<b>6</b>
<b>SPECIFICATIONS.....</b>	<b>9</b>
<b>EUROPEAN REGULATORY NOTES.....</b>	<b>10</b>
<b>EC DECLARATION OF CONFORMITY.....</b>	<b>10</b>
<b>DIRECTIVE 2002/95/EC (RoHS).....</b>	<b>10</b>
<b>DIRECTIVE 2002/96/EC (WEEE).....</b>	<b>10</b>
<b>INSTALLATION.....</b>	<b>12</b>
<b>VISUAL CHECK.....</b>	<b>12</b>
<b>POWER RATINGS.....</b>	<b>12</b>
<b>CONNECTION TO THE POWER SUPPLY.....</b>	<b>12</b>
<b>PROTECTION FROM ELECTRIC SHOCK.....</b>	<b>13</b>
<b>ENVIRONMENTAL CONDITIONS.....</b>	<b>14</b>
<b>FUSES.....</b>	<b>15</b>
<b>AC FUSE REPLACEMENT.....</b>	<b>15</b>
<b>DC FUSE REPLACEMENT.....</b>	<b>16</b>
<b>FUSE RATINGS.....</b>	<b>16</b>
<b>FRONT PANEL CONTROLS.....</b>	<b>17</b>
<b>REAR PANEL CONTROLS.....</b>	<b>19</b>
<b>PULSE GENERATOR TIMING.....</b>	<b>22</b>
<b>BASIC PULSE CONTROL.....</b>	<b>22</b>
<b>TRIGGER MODES.....</b>	<b>24</b>
<b>PULSE WIDTH MODES.....</b>	<b>24</b>
<b>GATING MODES.....</b>	<b>24</b>
<b>CONNECTING TO A POWER SUPPLY.....</b>	<b>25</b>
<b>GROUNDING ISSUES.....</b>	<b>25</b>
<b>USING THE 6 mm CONNECTORS.....</b>	<b>26</b>
<b>AK4 ACCESSORY KIT.....</b>	<b>28</b>
<b>KIT CONTENTS.....</b>	<b>28</b>
<b>SPECIFICATIONS.....</b>	<b>28</b>

GENERAL NOTES.....	29
REPLACEMENT PARTS AND OTHER ACCESSORIES.....	29
<b>CONNECTING TO THE LOAD.....</b>	<b>30</b>
HIGH-AVERAGE-POWER 6 mm OUTPUT CONNECTORS.....	30
LOW-AVERAGE-POWER DB-37 CONNECTOR.....	31
<b>SELECTING AN APPROPRIATE SERIES RESISTANCE.....</b>	<b>35</b>
<b>CURRENT MONITOR.....</b>	<b>36</b>
<b>ALARMS.....</b>	<b>36</b>
<b>START-UP CHECK-LIST FOR LOCAL CONTROL.....</b>	<b>37</b>
<b>PROGRAMMING YOUR PULSE GENERATOR.....</b>	<b>39</b>
KEY PROGRAMMING COMMANDS.....	39
ALL PROGRAMMING COMMANDS.....	39
<b>MECHANICAL INFORMATION.....</b>	<b>41</b>
TOP COVER REMOVAL.....	41
RACK MOUNTING.....	41
ELECTROMAGNETIC INTERFERENCE.....	41
<b>MAINTENANCE.....</b>	<b>42</b>
REGULAR MAINTENANCE.....	42
CLEANING.....	42
<b>WIRING DIAGRAMS.....</b>	<b>43</b>
WIRING OF AC POWER.....	43
PCB 158K - LOW VOLTAGE POWER SUPPLY, 1/3.....	44
PCB 158K - LOW VOLTAGE POWER SUPPLY, 2/3.....	45
PCB 158K - LOW VOLTAGE POWER SUPPLY, 3/3.....	46
PCB 104D - KEYPAD / DISPLAY BOARD, 1/3.....	47
PCB 104D - KEYPAD / DISPLAY BOARD, 2/3.....	48
PCB 104D - KEYPAD / DISPLAY BOARD, 3/3.....	49
PCB 116B - CURRENT MONITOR.....	50
PCB 94E - ALARM BOARD.....	51
PCB 186B - DRIVER.....	52
MAIN WIRING - POSITIVE UNITS (-P).....	53
<b>APPENDIX A - DC POWER SUPPLIES.....</b>	<b>54</b>
<b>PERFORMANCE CHECK SHEET.....</b>	<b>55</b>

Last modified March 16, 2006.  
Copyright © 2006 Avtech Electrosystems Ltd, All Rights Reserved.

## INTRODUCTION

The AVO-8C1-B-P pulse generator is designed for pulsing laser diodes and other low impedance loads with rectangular pulses as high as +40 Volts and +200 Amperes, pulse widths from 2 us to DC, and average output powers to 4000 Watts.

The AVO-8C1-B-P essentially acts as a high-current, high-speed switch for the output of a user-supplied DC power supply. The AVO-8C1-B-P is installed between the DC power supply and the load. The signal timing is controlled by the AVO-8C1-B-P, and the amplitude (output voltage) is controlled by the DC power supply. Avtech can recommend suitable DC power supplies for particular applications, if you do not already have one.

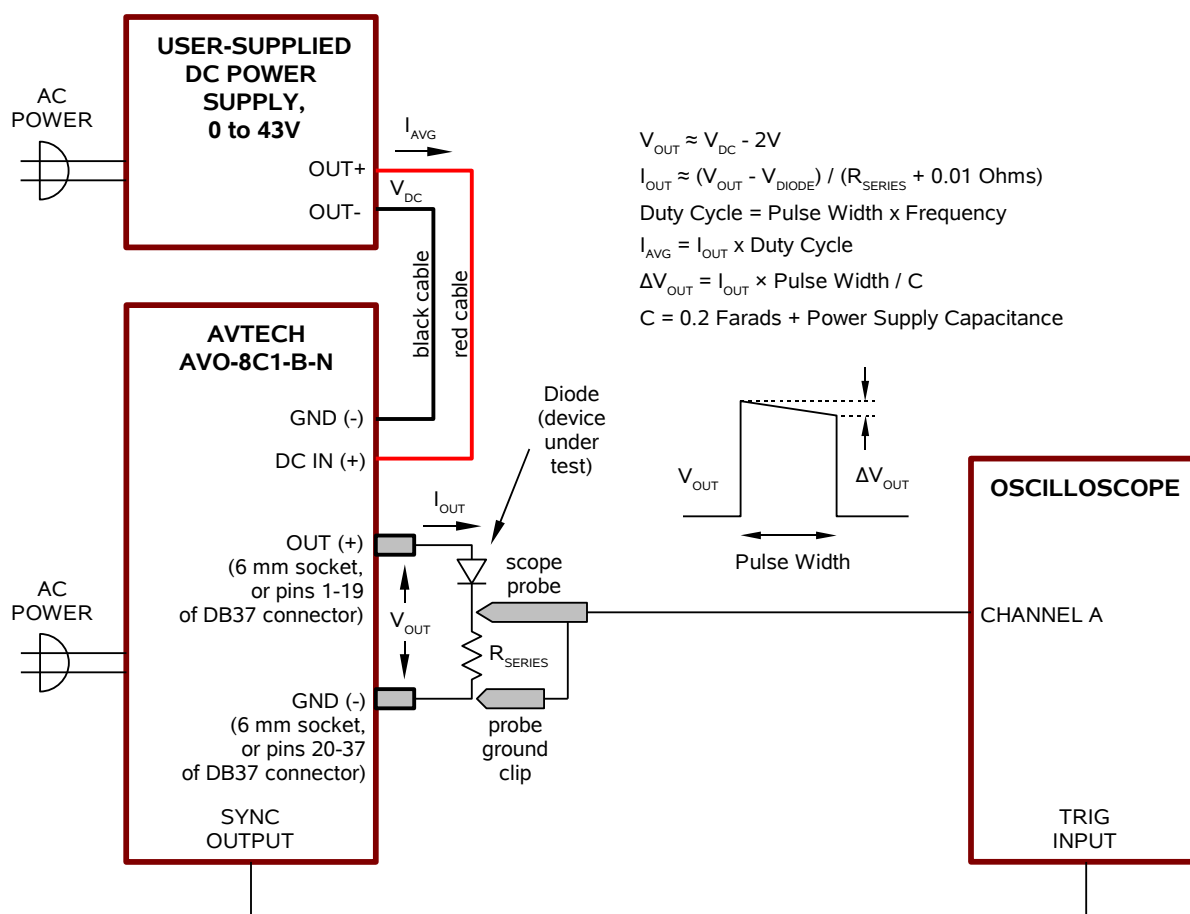

The output pulse amplitude (voltage) is controlled by the user-supplied high-current DC lab power supply that is connected to the AVO-8C1-B-P (see the diagram above). The AVO-8C1-B-P instrument acts as a high-efficiency, high-speed switch that connects the DC lab power supply to the load during the output pulse duration. The output is shorted to ground between pulses. The output pulse voltage amplitude is approximately equal to the lab power supply voltage minus 2 Volts. The lab power supply must be capable

of supplying at least the average value ( $I_{AVG}$ ) of the peak current supplied to the load ( $I_{OUT}$ ).  $I_{AVG}$ ,  $I_{OUT}$ , pulse width (PW) and frequency are related as shown in the diagram. Protective circuits monitor the lab power supply voltage level and the output circuit temperature and will automatically disable the triggering of the output stage if either the applied voltage or temperature exceed rated values.

The AVO-8C1-B-P is voltage pulser. A non-inductive resistor must be connected in series with the diode under test to limit the current to the maximum rated current (or less). The AVO-8C1-B-P will provide up to 200A to a load impedance as low as 0.2 Ohms. The AVO-8C1-B-P can operate at duty cycles up to 100% for currents of up to 100A. For higher peak currents, the duty cycle must be limited such that the average current is less than 100A.

The AVO-8C1-B-P consists of a single "3U" high (5.25") rack-mountable (19" wide) instrument mainframe. This model offers two output connector arrangements: a high-average-power connector optimized for high average power, and a lower-average-power connector optimized for fast rise times. (The two output connectors are wired in parallel to the same point internally.)

The high-average-power output connectors will accept 6 mm safety sockets, or 4 mm "banana" plugs. (6 mm safety sockets will have considerably higher current capability). Accessory kits with 1 meter lengths of cable with 6 mm sockets on each end, and mating 6 mm plug to M6 stud adapters are available for connecting to loads and power supplies. These cables introduce approximately 0.6 uH / meter of inductance, which will degrade the observed current rise times. (The rise time degradation introduced by an inductance L into a resistive load R is approximately  $2.2 \times L / R$ ). These connectors are preferred when the fastest possible rise time is not required.

The lower-average-power connector is a DB-37 female connector that will mate to Avtech AV-CLZ low impedance transmission lines (<http://www.avtechpulse.com/transmission/av-clz1>). This output is not rated for use above 75A of average current. However, the transmission line nature of the AV-CLZ cable and its low inductance ensure that the current rise time is not noticeably degraded by the cabling. The AV-CLZ cables must be ordered as an option (-AK6 option for a 60 cm cable), or they can be ordered as separate items. Longer cable lengths are available. See <http://www.avtechpulse.com/transmission/av-clz1> for model numbers.

For high duty cycle (> 50%) or wide pulse width (> 1 ms) applications the current rating of the lab power supply should be near the desired peak output load current, particularly if low output pulse droop is required. However, for low duty cycle applications (e.g. 10%) the current rating of the lab power supply may be considerably less than the desired peak load current because the large capacitance present in the AVO-8C1-B-P output circuit (200000 uF typically) provides the necessary high peak pulse current.

The pulse repetition frequency is variable from 1 Hz to 1 kHz using the internal oscillator. A delay control and a sync output are provided for oscilloscope triggering

purposes. A pushbutton is provided for one-shot operation. The units can also be triggered externally using a TTL-level pulse. The AVO-8C1-B-P includes a monitor output option that provides an attenuated coincident replica of the main output current pulse.

IEEE-488.2 GPIB and RS-232 control of pulse width, pulse repetition frequency, and delay is provided. These models include a front-panel keypad and adjust knob control of the output pulse parameters, along with a four line 40-character back-lit LCD display of the pulse width, pulse repetition frequency and delay. (Note that the DC power supply must be equipped with a GPIB feature, if you wish to remotely control the amplitude.) Optional telnet or web-based remote control is also available (<http://www.avtechpulse.com/options/tnt>), for control over local area networks or the internet.

The AVO-8C1-B-P offers an optional current limit feature. This function will disable the output if the current exceeds a set level. The response time of the limit circuit is  $< 5$   $\mu$ s. The trip level may be set from the front panel or by computer command. If the limit circuit is tripped the user must re-enable the output from the front panel or by computer command.

Visit the application note area of the Avtech web site (<http://www.avtechpulse.com/appnote>) for general applications assistance.

This instrument is intended for use in research, development, test and calibration laboratories by qualified personnel.



## SPECIFICATIONS

Model <sup>1</sup> :	AVO-8C1-B	
Amplitude:	current:	0 to 200 Amperes
	voltage:	0 to 40 Volts
Minimum load impedance: (required to limit output current)	0.2 $\Omega$	
Pulse width (FWHM):	2 $\mu$ s to 1 second, and DC <sup>5</sup> .	
Pulse repetition freq. (PRF):	1 Hz to 1 kHz	
Rise and fall times (20%-80%) <sup>11</sup> :	$\leq$ 1 $\mu$ s	
Maximum duty cycle:		
Normal PW mode:	<100A: 80%, >100A: 50%	
PW <sub>IN</sub> =PW <sub>OUT</sub> mode <sup>6</sup> :	<100A: 100%, >100A: 50%	
DC mode:	Usable up to 100A	
Max. average output current:	100 Amperes	
Output impedance:	$\leq$ 0.01 Ohms	
Polarity <sup>2</sup> :	Positive or negative (specify)	
Current limit function:	Optional <sup>12</sup> . Will disable the output if the current exceeds a set level. The trip level may be set from the front panel, or by computer command. Requires user intervention to re-enable the output. Trip level accuracy: $\pm 2\% \pm 1$ A. Response time: < 5 $\mu$ s.	
GPIO and RS-232 control <sup>1</sup> :	GPIO and RS-232 ports are standard on -B units.	
LabView drivers:	Check <a href="http://www.avtechpulse.com/labview">http://www.avtechpulse.com/labview</a> for availability and downloads	
Internet control <sup>3</sup> :	Optional on -B units. See <a href="http://www.avtechpulse.com/options/tnt">http://www.avtechpulse.com/options/tnt</a> for details.	
Propagation delay:	$\pm$ 100 ns (Ext trig in to pulse out)	
Jitter:	$\pm$ 500 ps $\pm$ 0.03% of sync delay (Ext trig in to pulse out)	
Trigger required, for external trigger modes:	External trigger, internal PW control mode: +5 Volt, 50 ns or wider (TTL) External trigger, external PW control mode: +5 Volt, PW <sub>IN</sub> = PW <sub>OUT</sub> (TTL)	
Monitor output:	Provides an attenuated coincident replica of the main output current pulse	
Sync delay, Sync output:	Sync out to pulse out: Variable 0 to $\pm$ 1 second. + 3 Volts, 100 ns, will drive 50 Ohm loads	
Gate input:	Synchronous or asynchronous, active high or low, switchable. Suppresses triggering when active.	
Burst mode option:	Optional <sup>9</sup> . Generates 1-500 pulses per trigger.	
Connectors (high-average-power):	6 mm plug / 4 mm sockets <sup>5</sup> (OUT yellow, GND green)	
Connectors (low-average-power):	DB-37 female. Pins 1-19 = signal, pins 20-37 = ground. Suitable for mating to AV-CLZ1 type cables ( <a href="http://www.avtechpulse.com/transmission/av-clz1">http://www.avtechpulse.com/transmission/av-clz1</a> ). Not for use for average currents greater than 75 Amps.	
Connectors (DC Power in):	6 mm plug / 4 mm sockets <sup>5</sup> (+ red, - black)	
Optional recommended accessory kits <sup>10</sup> :	-AK4 option: Provides four 1 meter cables (one each of red, black, green, yellow) with 6 mm safety sockets <sup>7</sup> , and four 6 mm safety plug to M6 stud adapters <sup>8</sup> (one each of red, black, green, yellow)  -AK6 option: Provides one AV-CLZ1-60 cable (60 cm length, Z <sub>0</sub> = 1 Ohm, see <a href="http://www.avtechpulse.com/transmission/av-clz1">http://www.avtechpulse.com/transmission/av-clz1</a> ) and one AV-CTLX cable-to-PCB adapter ( <a href="http://www.avtechpulse.com/accessories/av-ctlx">http://www.avtechpulse.com/accessories/av-ctlx</a> )	
Power requirements:	DC <sup>4</sup> :	0 to 42 V, 200 Amp max
	AC:	100 - 240 Volts, 50 - 60 Hz
Cooling:	Self-contained fan.	
Dimensions:	Mainframe:	138 mm x 430 mm x 425 mm (5.5" x 17" x 16.8")
Rack-mount kit:	Add the suffix -R6 to the model number to include 19" rack mount kit.	
Chassis material:	Anodized aluminum, with blue plastic trim	
Temperature range:	+5°C to +40°C	

1) -B suffix indicates IEEE-488.2 GPIO and RS-232 control of pulse width, PRF and delay. (See <http://www.avtechpulse.com/gpio> for details).

2) Indicate desired polarity by suffixing the model number with -P or -N (i.e. positive or negative).

3) Add the suffix -TNT to the model number to specify the Internet control (Telnet and Web) option.

4) Requires a user-supplied DC power supply. Avtech suggests Xantrex as a source of DC power supplies (<http://www.xantrex.com>). Contact Avtech for recommendations about DC power supplies appropriate for your application. The cables for connecting the external DC power supply are not included with the standard model. 6 mm plug to 6 mm plug cables are available in the optional -AK3 and -AK4 accessory kits. These may or may not be suitable for your power supply, depending on the power supply's connectors. It is possible to cut and strip the ends of the optional accessory cables, and to attach other terminations. Multi-Contact (<http://www.multi-contact.com> or <http://www.multi-contact-usa.com>) can supply 6 mm plug to cable lug cables, and other configurations.

5) When externally triggered, the output pulse width can be controlled by the front panel controls (or computer command), or it can be set to follow the input pulse width (i.e., PW<sub>IN</sub>=PW<sub>OUT</sub> mode).

6) Multi-Contact (<http://www.multi-contact.com> or <http://www.multi-contact-usa.com>) ID/S6AR-N-B4S series, or similar.

7) Multi-Contact (<http://www.multi-contact.com> or <http://www.multi-contact-usa.com>) SLK616-AR/BGG series, or similar.

8) PDISS  $\approx$  ILOAD2  $\times$  0.01 $\Omega$   $\times$  Duty Cycle.

9) Add the suffix -BR to the model number to specify the burst mode option. See <http://www.avtechpulse.com/options/br> for details about this option.

10) Add the suffix(es) -AK3, -AK4, and/or -AK6 as appropriate, to the model number to include the accessory kit(s).

11) Valid for non-inductive loads installed directly on the output connectors (i.e., zero cable length) using low-inductance adapters, or for loads installed directly on the end of a AV-CLZ1-60 cable plugged into the DB-37 output connector. Inductive loads or cables will degrade the rise times. The 6 mm cables supplied with the optional accessory kits have an inductance of 0.6  $\mu$ H / meter, approximately. The rise time degradation can be estimated as  $2.2 \times D \times L / R$ , where D is the cable length, L = 0.6  $\mu$ H/m, and R is the load resistance. With a 2m cable length and a 0.2 $\Omega$  load, the rise time would degrade by 13.2  $\mu$ s. The AV-CLZ1-60 transmission lines do not display this inductive effect.

12) Add the suffix -TRIP to the model number to specify the current limit function. Units without this option will still have an over-current protection feature, but the trip level will be non-adjustable and set 20% above the maximum rated current, approximately.

## EUROPEAN REGULATORY NOTES

### EC DECLARATION OF CONFORMITY

We                    Avtech Electrosystems Ltd.  
                         P.O. Box 5120, LCD Merivale  
                         Ottawa, Ontario  
                         Canada K2C 3H4

declare that this pulse generator meets the intent of Directive 89/336/EEC for Electromagnetic Compatibility. Compliance pertains to the following specifications as listed in the official Journal of the European Communities:

EN 50081-1 Emission

EN 50082-1 Immunity

and that this pulse generator meets the intent of the Low Voltage Directive 72/23/EEC as amended by 93/68/EEC. Compliance pertains to the following specifications as listed in the official Journal of the European Communities:

EN 61010-1:2001 Safety requirements for electrical equipment for measurement, control, and laboratory use



### DIRECTIVE 2002/95/EC (RoHS)

This instrument is exempt from Directive 2002/95/EC of the European Parliament and of the Council of 27 January 2003 on the Restriction of the use of certain Hazardous Substances (RoHS) in electrical and electronic equipment. Specifically, Avtech instruments are considered "Monitoring and control instruments" (Category 9) as defined in Annex 1A of Directive 2002/96/EC. The Directive 2002/95/EC only applies to Directive 2002/96/EC categories 1-7 and 10, as stated in the "Article 2 - Scope" section of Directive 2002/95/EC.

### DIRECTIVE 2002/96/EC (WEEE)

European customers who have purchased this equipment directly from Avtech will have completed a "WEEE Responsibility Agreement" form, accepting responsibility for

WEEE compliance (as mandated in Directive 2002/96/EC of the European Union and local laws) on behalf of the customer, as provided for under Article 9 of Directive 2002/96/EC.

Customers who have purchased Avtech equipment through local representatives should consult with the representative to determine who has responsibility for WEEE compliance. Normally, such responsibilities will lie with the representative, unless other arrangements (under Article 9) have been made.

Requirements for WEEE compliance may include registration of products with local governments, reporting of recycling activities to local governments, and financing of recycling activities.

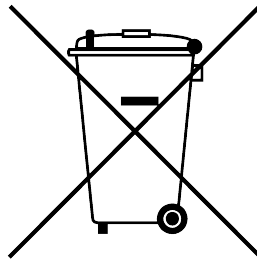

## INSTALLATION

### VISUAL CHECK

After unpacking the instrument, examine to ensure that it has not been damaged in shipment. Visually inspect all connectors, knobs, liquid crystal displays (LCDs), and the handles. If the instrument has been damaged, file a claim immediately with the company that transported the instrument.

Confirm that the following items are present:

- The mainframe (i.e., the main instrument chassis)
- A power cord
- A GPIB cable
- Two instrumentation manuals (this manual and the “Programming Manual for -B Instruments”) are with the instrument.

If the -AK4 option has been specified, the following should also be present:

- Four 1 m cables (one each of red, black, green, yellow) with 6 mm safety sockets
- Four 6 mm safety plug to M6 stud adapters<sup>6</sup> (one each of red, black, green, yellow)

If the -AK6 option has been specified, the following should also be present:

- One AV-CLZ1-60 rugged connectorized transmission line, 60 cm long
- One AV-CTLX cable-to-PCB adapter

### POWER RATINGS

This instrument is intended to operate from 100 - 240 V, 50 - 60 Hz.

The maximum power consumption is 57 Watts. Please see the “FUSES” section for information about the appropriate AC and DC fuses.

This instrument is an “Installation Category II” instrument, intended for operation from a normal single-phase supply.

### CONNECTION TO THE POWER SUPPLY

An IEC-320 three-pronged recessed male socket is provided on the back panel for AC power connection to the instrument. One end of the detachable power cord that is supplied with the instrument plugs into this socket. The other end of the detachable power cord plugs into the local mains supply. Use only the cable supplied with the instrument. The mains supply must be earthed, and the cord used to connect the

instrument to the mains supply must provide an earth connection. (The supplied cord does this.)

 Warning: Failure to use a grounded outlet may result in injury or death due to electric shock. This product uses a power cord with a ground connection. It must be connected to a properly grounded outlet. The instrument chassis is connected to the ground wire in the power cord.

The table below describes the power cord that is normally supplied with this instrument, depending on the destination region:

Destination Region	Description	Manufacturer	Part Number
Continental Europe	European CEE 7/7 "Schuko" 230V, 50Hz	Volex ( <a href="http://www.volex.com">http://www.volex.com</a> )	17850-C3-326
		Qualtek ( <a href="http://www.qualtekusa.com">http://www.qualtekusa.com</a> )	319004-T01
United Kingdom	BS 1363, 230V, 50Hz	Qualtek ( <a href="http://www.qualtekusa.com">http://www.qualtekusa.com</a> )	370001-E01
Switzerland	SEV 1011, 2 30V, 50Hz	Volex ( <a href="http://www.volex.com">http://www.volex.com</a> )	2102H-C3-10
Israel	SI 32, 220V, 50Hz	Volex ( <a href="http://www.volex.com">http://www.volex.com</a> )	2115H-C3-10
North America, and all other areas	NEMA 5-15, 120V, 60 Hz	Qualtek ( <a href="http://www.qualtekusa.com">http://www.qualtekusa.com</a> )	312007-01

## PROTECTION FROM ELECTRIC SHOCK

 Operators of this instrument must be protected from electric shock at all times. The owner must ensure that operators are prevented access and/or are insulated from every connection point. In some cases, connections must be exposed to potential human contact. Operators must be trained to protect themselves from the risk of electric shock. This instrument is intended for use by qualified personnel who recognize shock hazards and are familiar with safety precautions required to avoid possibly injury. In particular, operators should:

1. Keep exposed high-voltage wiring to an absolute minimum.
2. Wherever possible, use shielded connectors and cabling.
3. Connect and disconnect loads and cables only when the instrument is turned off.
4. Keep in mind that all cables, connectors, oscilloscope probes, and loads must have an appropriate voltage rating.
5. Do not attempt any repairs on the instrument, beyond the fuse replacement procedures described in this manual. Contact Avtech technical support (see

page 2 for contact information) if the instrument requires servicing. Service is to be performed solely by qualified service personnel.

### ENVIRONMENTAL CONDITIONS

This instrument is intended for use under the following conditions:

1. indoor use;
2. altitude up to 2 000 m;
3. temperature 5 °C to 40 °C;
4. maximum relative humidity 80 % for temperatures up to 31 °C decreasing linearly to 50 % relative humidity at 40 °C;
5. Mains supply voltage fluctuations up to  $\pm 10$  % of the nominal voltage;
6. no pollution or only dry, non-conductive pollution.

## FUSES

This instrument contains four fuses. All are accessible from the rear-panel. Two protect the AC prime power input, and two protect the internal DC power supplies. The locations of the fuses on the rear panel are shown in the figure below:

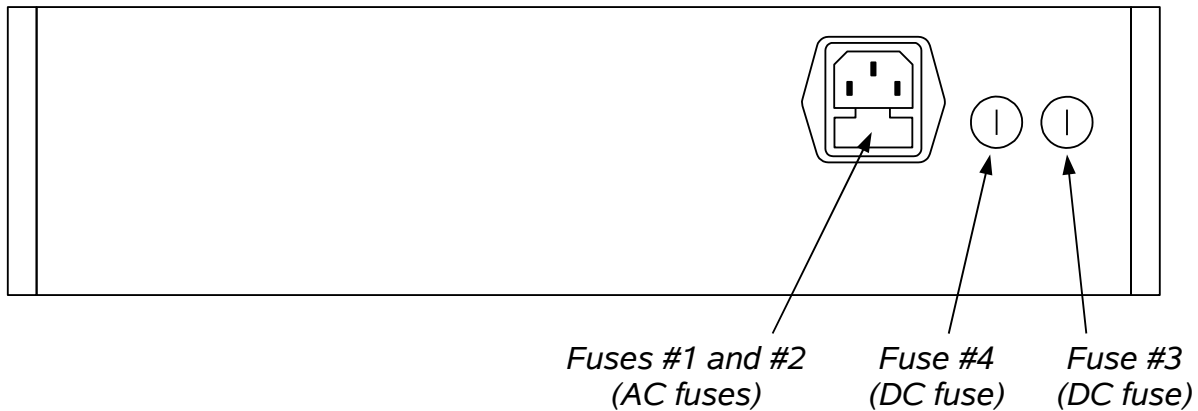

### AC FUSE REPLACEMENT

To physically access the AC fuses, the power cord must be detached from the rear panel of the instrument. The fuse drawer may then be extracted using a small flat-head screwdriver, as shown below:

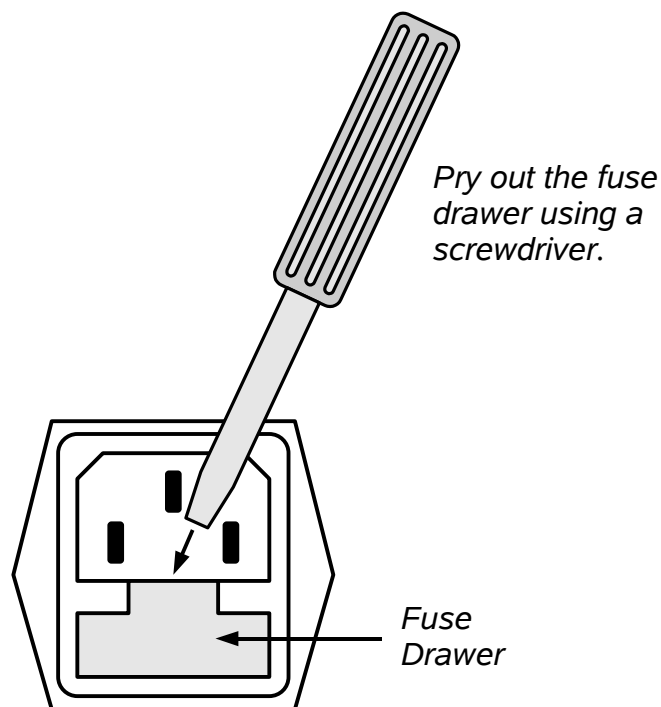

## DC FUSE REPLACEMENT

The DC fuses may be replaced by inserting the tip of a flat-head screwdriver into the fuse holder slot, and rotating the slot counter-clockwise. The fuse and its carrier will then pop out.

## FUSE RATINGS

The following table lists the required fuses:

Fuses	Nominal Mains Voltage	Rating	Case Size	Manufacturer's Part Number (Wickmann)	Distributor's Part Number (Digi-Key)
#1, #2 (AC)	100-240V	0.5A, 250V, Time-Delay	5×20 mm	1950500000	WK5041-ND
#3 (DC)	N/A	1.0A, 250V, Time-Delay	5×20 mm	1951100000	WK5048-ND
#4 (DC)	N/A	Not used. A spare 1.0A fuse is installed here.			

The fuse manufacturer is Wickmann (<http://www.wickmann.com/>).

Replacement fuses may be easily obtained from Digi-Key (<http://www.digikey.com/>) and other distributors.



## FRONT PANEL CONTROLS

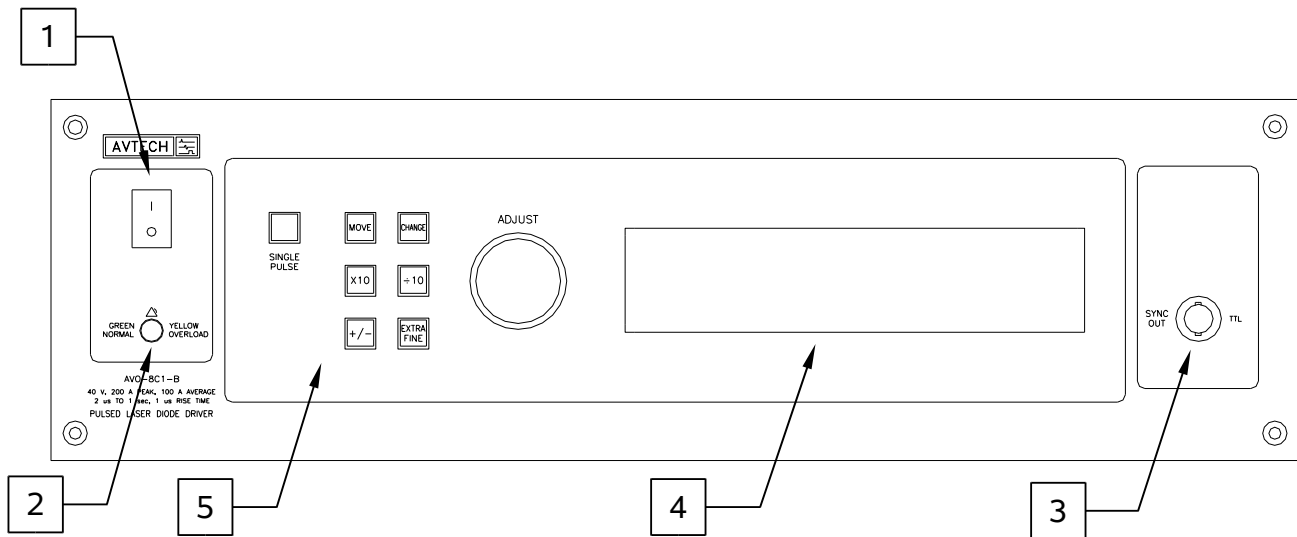

1. **POWER Switch.** This is the main power switch. When turning the instrument on, there may be a delay of several seconds before the instrument appears to respond.
2. **OVERLOAD Indicator.** When the instrument is powered, this indicator is normally green, indicating normal operation. If this indicator is yellow, an internal automatic overload protection circuit has been tripped. If the unit is overloaded (by operating at an exceedingly high duty cycle or by operating into a very low impedance), the protective circuit will disable the output of the instrument and turn the indicator light yellow. The light will stay yellow (i.e. output disabled) for about 5 seconds after which the instrument will attempt to re-enable the output (i.e. light green) for about 1 second. If the overload condition persists, the output will be disabled again (i.e. light yellow) for another 5 seconds. If the overload condition has been removed, the instrument will resume normal operation.

This overload indicator may flash yellow briefly at start-up. This is not a cause for concern.

Note that the output stage will safely withstand a short-circuited load condition.

3. **SYNC OUT.** This connector supplies a SYNC output that can be used to trigger other equipment, particularly oscilloscopes. This signal leads (or lags) the main output by a duration set by the "DELAY" controls and has an approximate amplitude of +3 Volts to  $R_L > 50\Omega$  with a pulse width of approximately 200 ns.
4. **LIQUID CRYSTAL DISPLAY (LCD).** This LCD is used in conjunction with the keypad to change the instrument settings. Normally, the main menu is displayed, which lists the key adjustable parameters and their current values. The "Programming Manual for -B Instruments" describes the menus and submenus in detail.

5. KEYPAD.

Control Name	Function
MOVE	This moves the arrow pointer on the display.
CHANGE	This is used to enter the submenu, or to select the operating mode, pointed to by the arrow pointer.
×10	If one of the adjustable numeric parameters is displayed, this increases the setting by a factor of ten.
÷10	If one of the adjustable numeric parameters is displayed, this decreases the setting by a factor of ten.
+/-	If one of the adjustable numeric parameters is displayed, and this parameter can be both positive or negative, this changes the sign of the parameter.
EXTRA FINE	This changes the step size of the ADJUST knob. In the extra-fine mode, the step size is twenty times finer than in the normal mode. This button switches between the two step sizes.
ADJUST	This large knob adjusts the value of any displayed numeric adjustable values, such as frequency, pulse width, etc. The adjust step size is set by the "EXTRA FINE" button.  When the main menu is displayed, this knob can be used to move the arrow pointer.

## REAR PANEL CONTROLS

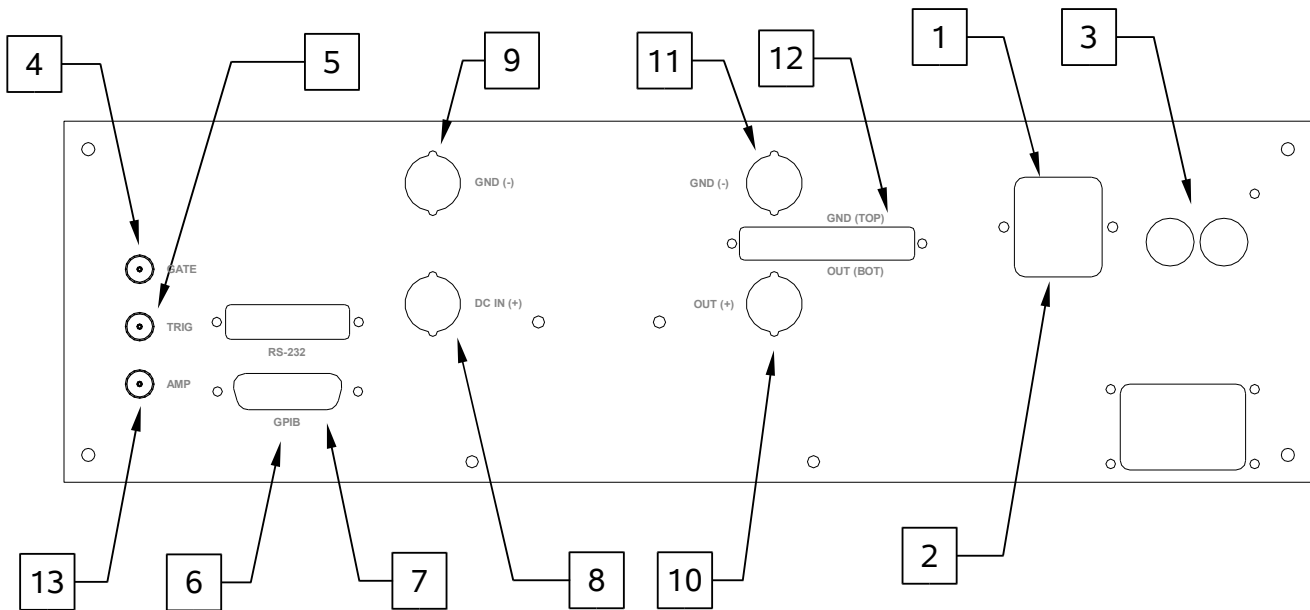

1. **AC POWER INPUT.** An IEC-320 C14 three-pronged recessed male socket is provided on the back panel for AC power connection to the instrument. One end of the detachable power cord that is supplied with the instrument plugs into this socket.
2. **AC FUSE DRAWER.** The two fuses that protect the AC input are located in this drawer. Please see the “FUSES” section of this manual for more information.
3. **DC FUSES.** These two fuses protect the internal DC power supplies. Please see the “FUSES” sections of this manual for more information.
4. **GATE.** This TTL-level (0 and +5V) logic input can be used to gate the triggering of the instrument. This input can be either active high or active low, depending on the front panel settings or programming commands. (The instrument triggers normally when this input is unconnected). When set to active high mode, this input is pulled-down to ground by a 1 k $\Omega$  resistor. When set to active low mode, this input is pulled-up to +5V by a 1 k $\Omega$  resistor.
5. **TRIG.** This TTL-level (0 and +5V) logic input can be used to trigger the instrument, if the instrument is set to triggering externally. The instrument triggers on the rising edge of this input. The input impedance of this input is 1 k $\Omega$ . (Depending on the length of cable attached to this input, and the source driving it, it may be desirable to add a coaxial 50 Ohm terminator to this input to provide a proper transmission line termination. The Pasternack ([www.pasternack.com](http://www.pasternack.com)) PE6008-50 BNC feed-thru 50 Ohm terminator is suggested for this purpose.)

When triggering externally, the instrument can be set such that the output pulse

width tracks the pulse width on this input, or the output pulse width can be set independently.

 Do not exceed a repetition rate of 1 kHz when triggering externally. Excessive repetition rates may cause over-heating internally, and possible damage the instrument.

6.  GPIB Connector. A standard GPIB cable can be attached to this connector to allow the instrument to be computer-controlled. See the “Programming Manual for -B Instruments” for more details on GPIB control.
7.  RS-232 Connector. A standard serial cable with a 25-pin male connector can be attached to this connector to allow the instrument to be computer-controlled. See the “Programming Manual for -B Instruments” for more details on RS-232 control.
8.  DC IN (+) Connector. This power input connector must be connected to the positive (+) output of the user-supplied external DC power supply. This connector will accept 6 mm safety sockets, or 4 mm "banana" plugs. (6 mm safety sockets will have considerably higher current capability). Beware that the 6 mm cables "lock" into the mating adapters. **To release the lock, push the cable inwards FIRST, and THEN pull it out of the adapter.** The cable will not be released if you simply pull on it.
9.  GND (-) Connector. This power input connector must be connected to the negative (-) output of the user-supplied external DC power supply. This connector will accept 6 mm safety sockets, or 4 mm "banana" plugs. (6 mm safety sockets will have considerably higher current capability). Beware that the 6 mm cables "lock" into the mating adapters. **To release the lock, push the cable inwards FIRST, and THEN pull it out of the adapter.** The cable will not be released if you simply pull on it.
10.  OUT (+) Connector. This is the high-average-power output connector (one of the two output connector provided - see also item 12). This connector will accept 6 mm safety sockets, or 4 mm "banana" plugs. (6 mm safety sockets will have considerably higher current capability). Beware that the 6 mm cables "lock" into the mating adapters. **To release the lock, push the cable inwards FIRST, and THEN pull it out of the adapter.** The cable will not be released if you simply pull on it.
11.  GND (-) Connector. This is the ground return associated with the high-average-power output connector (item 10). This connector will accept 6 mm safety sockets, or 4 mm "banana" plugs. (6 mm safety sockets will have considerably higher current capability). Beware that the 6 mm cables "lock" into the mating adapters. **To release the lock, push the cable inwards FIRST, and THEN pull it out of the adapter.** The cable will not be released if you simply pull on it.
12.  DB37 OUT/GND Connector. This is the low-average-power output and ground connector (one of the two output connector provided - see also item 10). Pins 1-19 (the bottom row) carry the output signal, and pins 20-37 (the top row) are the ground return. The connector is suitable for mating to Avtech AV-CLZ1 type cables

(<http://www.avtechpulse.com/transmission/av-clz1>). Not for use for average currents greater than 75 Amps.

13. AMP Connector. This is a current monitor output. This output provides a voltage waveform that is proportional to the current waveform on the output. The monitor relationship is:  $V_{MON} = I_{OUT} \times 1V/50A$ , for a load of  $> 1 \text{ k}\Omega$ . (The monitor output can also drive a  $50\Omega$  load, but the output voltage will be reduced by a factor of 2. This output is short-circuit protected.) The monitor loses accuracy for pulse widths of 10 us and less.

## PULSE GENERATOR TIMING

### BASIC PULSE CONTROL

This instrument can be triggered by its own internal clock or by an external TTL trigger signal. In either case, two output channels respond to the trigger: OUT and SYNC. The OUT channel is the signal that is applied to the load. Its amplitude and pulse width are variable. The SYNC pulse is a fixed-width TTL-level reference pulse used to trigger oscilloscopes or other measurement systems. When the delay is set to a positive value the SYNC pulse precedes the OUT pulse. When the delay is set to a negative value the SYNC pulse follows the OUT pulse.

These pulses are illustrated below, assuming internal triggering and positive delay:

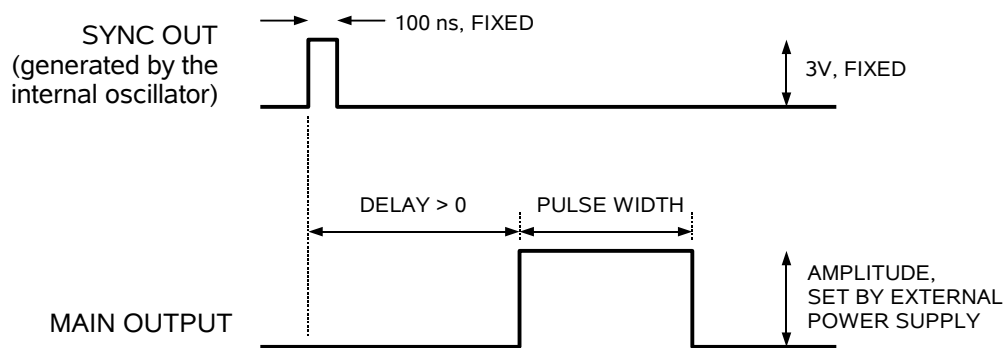

If the delay is negative, the order of the SYNC and OUT pulses is reversed:

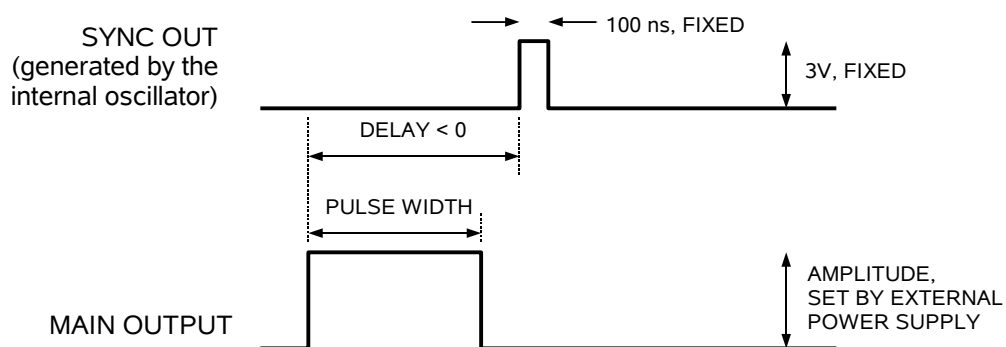

The next figure illustrates the relationship between the signals when an external TTL-level trigger is used:

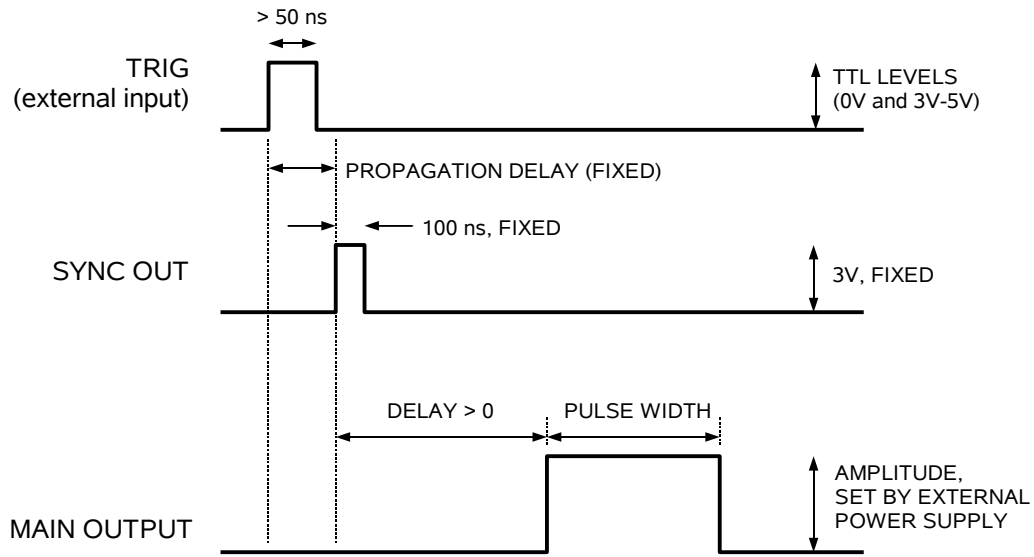

As before, if the delay is negative, the order of the SYNC and OUT pulses is reversed.

The last figure illustrates the relationship between the signal when an external TTL-level trigger is used in the  $PW_{IN}=PW_{OUT}$  mode. In this case, the output pulse width equals the external trigger's pulse width (approximately), and the delay circuit is bypassed:

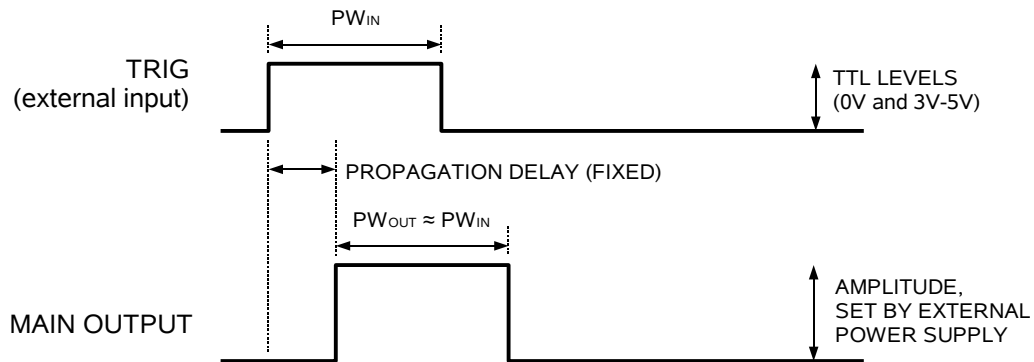

The delay, pulse width, and frequency (when in the internal mode), of the main output pulse can be varied with front panel controls or via the GPIB or RS-232 computer interfaces.

In all modes, the amplitude of the main output pulse is controlled by the DC voltage applied across the DC IN (+) and GND (-) connectors on the rear panel. This voltage is generated by the user-supplied external DC power supply.

 Do not exceed a repetition rate of 1 kHz when triggering externally. Excessive repetition rates may cause over-heating internally, and possible damage the instrument.

## TRIGGER MODES

This instrument has four trigger modes:

- Internal Trigger: the instrument controls the trigger frequency, and generates the clock internally.
- External Trigger: the instrument is triggered by an external TTL-level clock on the back-panel TRIG connector.
- Manual Trigger: the instrument is triggered by the front-panel “SINGLE PULSE” pushbutton.
- Hold Trigger: the instrument is set to not trigger at all.

These modes can be selected using the front panel trigger menu, or by using the appropriate programming commands. (See the “Programming Manual for -B Instruments” for more details.)

## PULSE WIDTH MODES

This instrument has two pulse width modes:

- Normal: the instrument controls the output pulse width.
- $PW_{IN}=PW_{OUT}$ : the output pulse width equals the pulse width of the trigger signal on the “TRIG” connector. The instrument must be in the external trigger mode.

These modes can be selected using the front panel pulse width menu, or by using the appropriate programming commands. (See the “Programming Manual for -B Instruments” for more details.)

## GATING MODES

Triggering can be suppressed by a TTL-level signal on the rear-panel GATE connector. The instrument can be set to stop triggering when this input high or low, using the front-panel gate menu or the appropriate programming commands. This input can also be set to act synchronously or asynchronously. When set to asynchronous mode, the GATE will disable the output immediately. Output pulses may be truncated. When set to synchronous mode, the output will complete the full pulse width if the output is high, and then stop triggering. No pulses are truncated in this mode.



CONNECTING TO A POWER SUPPLY

The basic connection arrangement for the AVO-8C1-B-P is shown below. The AVO-8C1-B-P must be connected to a user-supplied external DC power supply. Specifically, the "DC IN (+)" rear-panel connector (which is identified with a red ring) should be connected to the positive output of the power supply, and the "GND (-)" rear-panel connector (which is identified with a black ring) should be connected to the negative output of the power supply. If the AVO-8C1-B-P has been ordered with the -AK4 accessory kit, the included red and black cables are suggested for this purpose.

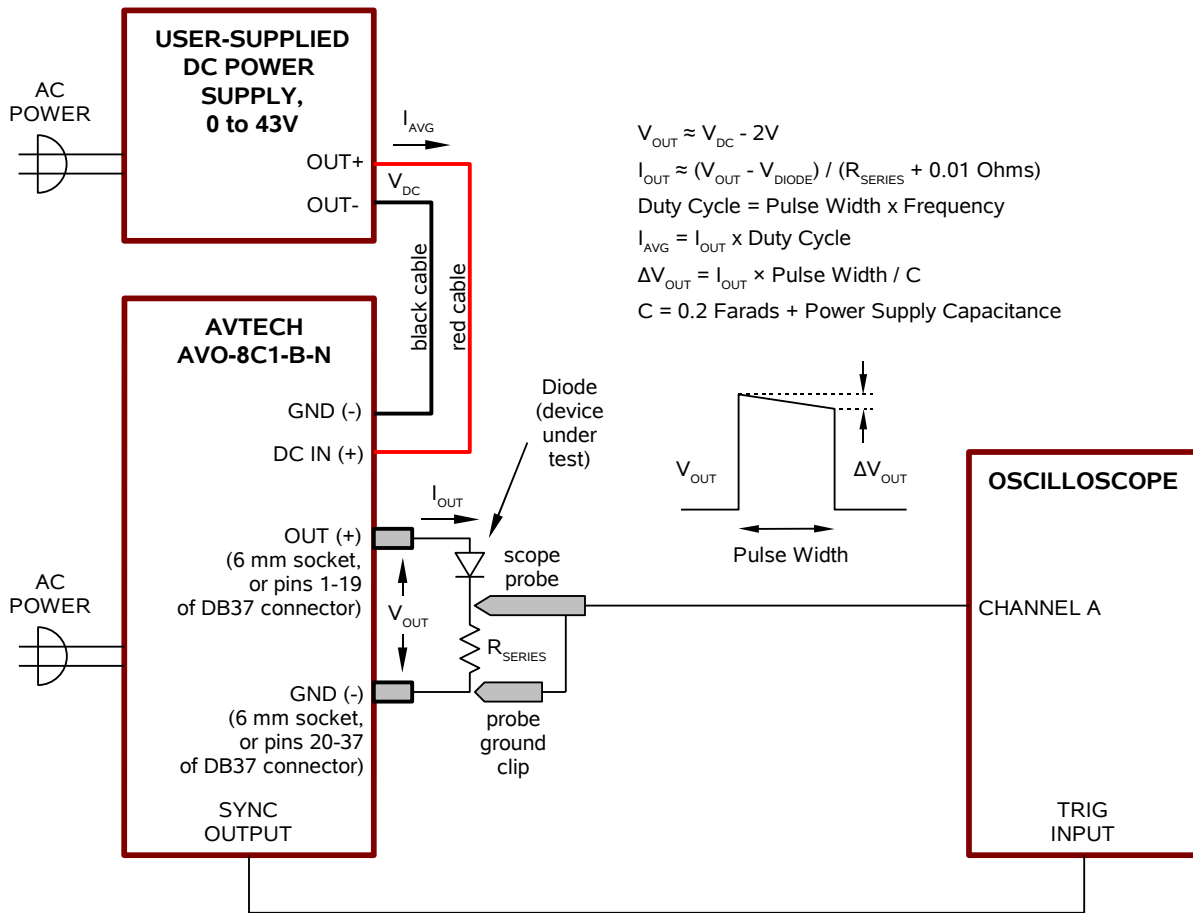

Possible DC power supplies for use with the AVO-8C1-B-P are listed in Appendix A.

GROUNDING ISSUES

To avoid ground loops that might distort measurements, the power supply terminals (OUT- and OUT+) should not normally be connected or jumpered to any ground terminals on the power supply chassis. Instead, ground the "GND (-)" output by

connecting it to the measurement system ground. The two "GND (-)" connectors on the rear panel are not internally connected to the chassis or AC grounds.

In the diagram above, the output "GND (-)" terminal is connected to the ground clip on the oscilloscope probe.

### USING THE 6 mm CONNECTORS

The four 6 mm connectors on the rear panel are designed to accept cables terminated with 6 mm sockets or 4 mm "banana" plugs.

4 mm "banana" plug cables are quite common, and are used with many lower-current DC power supplies. However, if you intend to operate at high average currents ( $I_{AVG} > 15$  Amps) then they are probably unsuitable, and 6 mm socket cables should be used instead.

The higher-current 6 mm socket cables are less common. See the "AK4 Accessory Kit Section" for details about suitable cables and adapters.

Beware that the 6 mm cables "lock" into the mating adapters. **To release the lock, push the cable inwards FIRST, and THEN pull it out of the adapter.** The cable will not be released if you simply pull on it.

A typical power supply to pulser connection is shown below.

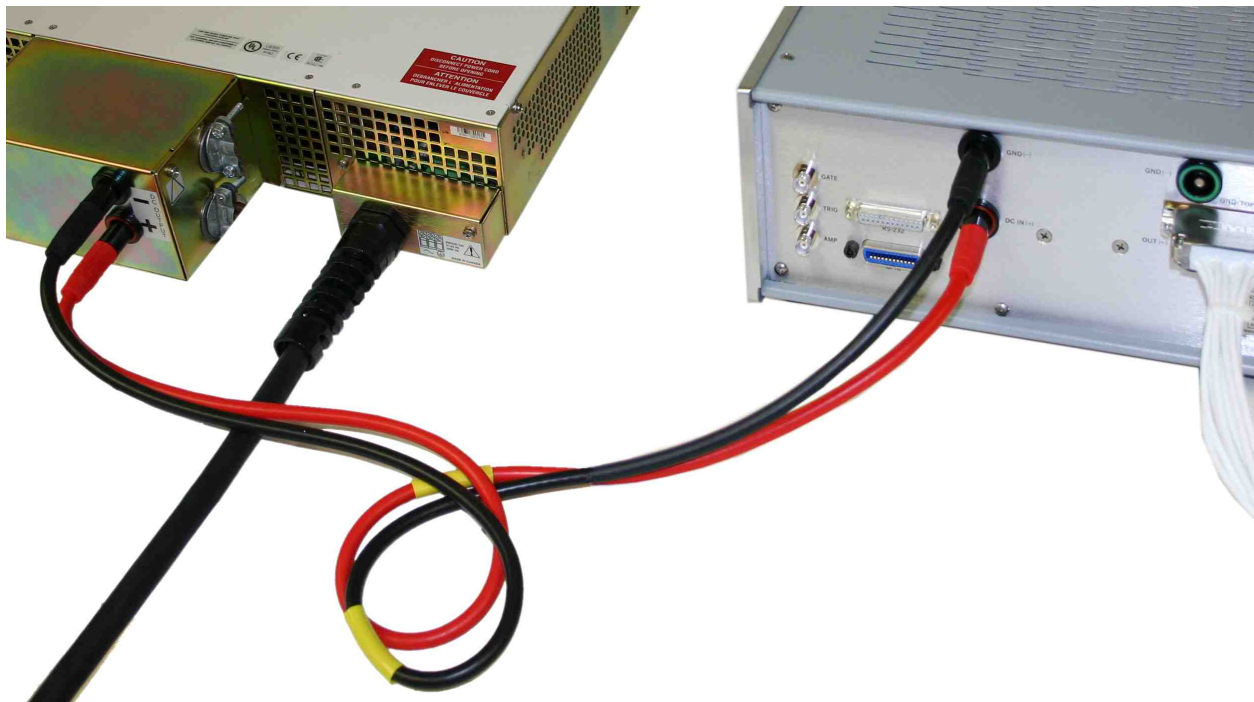

The next photo shows how 4 mm "banana" cables will also mate to the DC power input connectors:

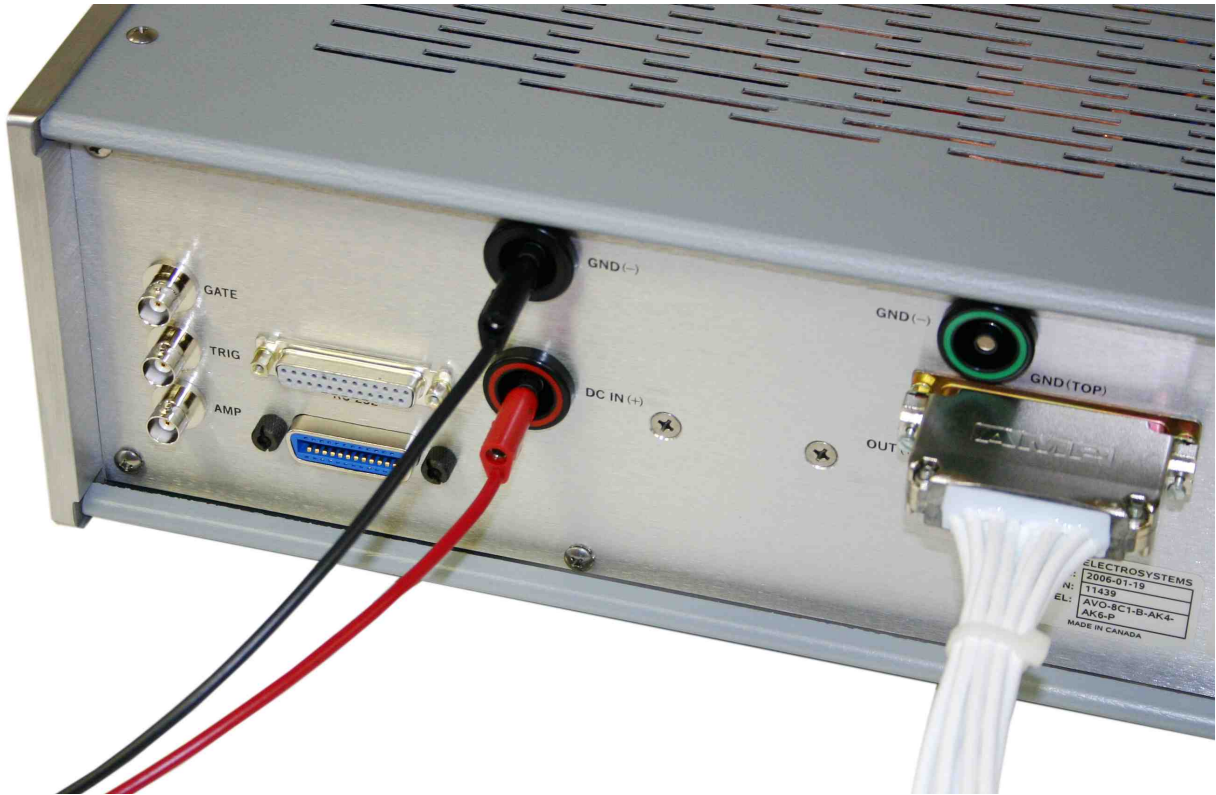

## AK4 ACCESSORY KIT

The optional AK4 accessory kit contains a number of cables and adapters that are useful for connecting the AVO-8C1-B-P to the DC power supply and the load.

### KIT CONTENTS

The AK4 accessory kit contains four cables (one each of red, black, yellow, and green), terminated with 6 mm safety sockets, and four 6 mm safety plug to M4 stud adapters (one of each color), as shown below:



### SPECIFICATIONS

Type	Series	Color	Part Number	Rated Current (DC)	Rated Current (1 sec pulse)
1 meter Cable with 6 mm safety sockets	Multi-Contact SLK616-AR/BGG	Red	15.2502-100-22	100 A	1200 A
		Black	15.2502-100-21		
		Yellow	15.2502-100-24		
		Green	15.2502-100-25		
6 mm safety plug to M4 stud adapter	Multi-Contact ID/S6AR-N-B4S	Red	14.0034-22	100 A	1200 A
		Black	14.0034-21		
		Yellow	14.0034-24		
		Green	14.0034-25		

## GENERAL NOTES

The red and black cables are typically used to connect an Avtech pulse generator to a DC power supply (red = +, black = -). If your DC power supply does not provide its outputs on 6 mm safety plugs, then it may be necessary to use the red and black 6 mm safety plug to M4 stud adapters to build an appropriate connection to your power supply.

The yellow and green cables are typically plugged directly into the matching 6 mm plug connectors on the rear panel of an Avtech high-current pulse generator. The yellow and green 6 mm safety plug to M4 stud adapters are provided so that an appropriate connection may be made to your load.

Beware that these 1 meter cables have an inductance of approximately 0.6  $\mu$ H, and they may not be appropriate for high-speed use. The inductance will introduce an inductive time constant of  $\tau = L / R$ , where  $L = 0.6 \mu\text{H}$ , and  $R =$  your load resistance. It may be necessary to trim the cables for faster speeds.

The cables "lock" into the mating adapters. ***To release the lock, push the cable inwards FIRST, and THEN pull it out of the adapter.*** The cable will not be released if you simply pull on it.

## REPLACEMENT PARTS AND OTHER ACCESSORIES

The parts in this accessory kit, and other mating accessories, are available individually from the manufacturer, Multi-Contact (see <http://www.multi-contact-usa.com> or <http://www.multi-contact.com>).

## CONNECTING TO THE LOAD

This model offers two output connector arrangements: a high-average-power connector optimized for high average power, and a lower-average-power connector optimized for fast rise times. (The two output connectors are wired in parallel to the same point internally.)

### HIGH-AVERAGE-POWER 6 mm OUTPUT CONNECTORS

The high-average-power output connectors are the same type as those used for the DC power inputs, and they will accept 6 mm safety sockets, or 4 mm "banana" plugs. (6 mm safety sockets will have considerably higher current capability). Accessory kits with 1 meter lengths of cable with 6 mm sockets on each end, and mating 6 mm plug to M6 stud adapters are available for connecting to loads and power supplies. These cables introduce approximately 0.6  $\mu\text{H}$  / meter of inductance, which will degrade the observed current rise times. (The rise time degradation introduced by an inductance  $L$  into a resistive load  $R$  is approximately  $2.2 \times L / R$ ). These connectors are preferred when the fastest possible rise time is not required.

An example setup using these connectors is shown in the photo below:

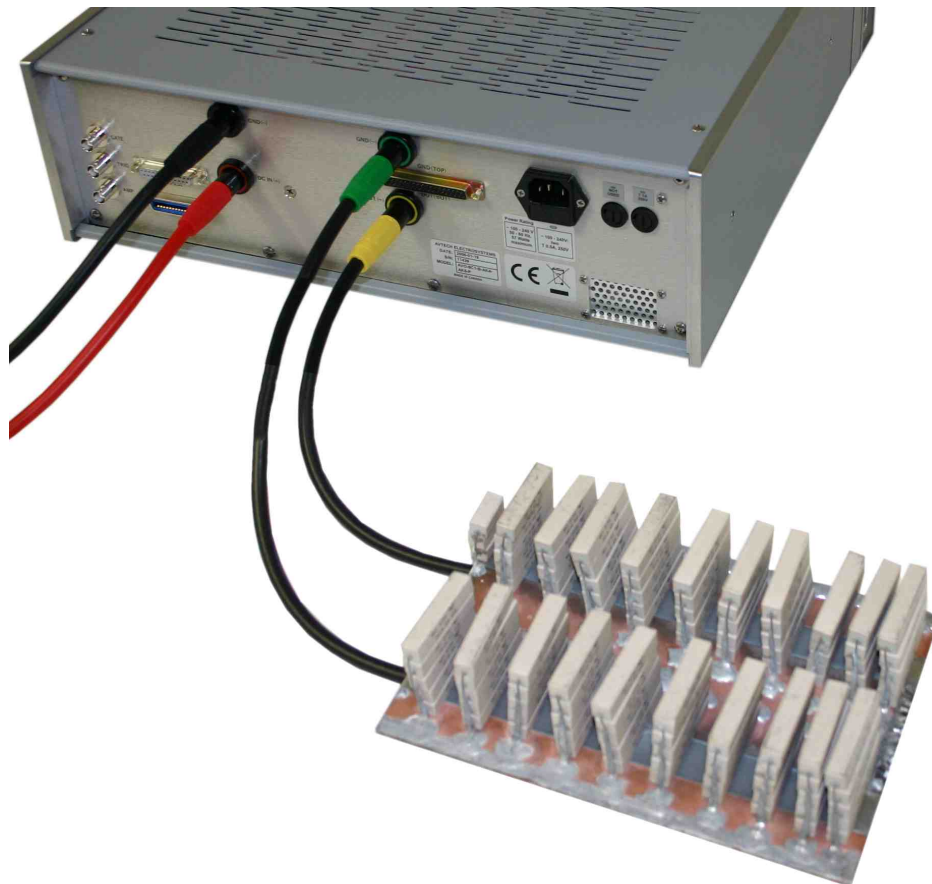

In the setup shown above, a bank of two-hundred  $20\Omega$  resistors wired in parallel is connected to the pulser using the 6 mm cables. (At the load, the cables are soldered directly to the circuit board).

The inductance of the 6 mm cables degrades the rise and fall times. For 45 cm lengths of 6 mm cable on the output and ground lines, the rise time degradation is approximately  $2.2 \times (45 \text{ cm} \times 2 \times 0.6 \text{ uH / meter}) / 0.2 \text{ Ohms} = 6 \text{ us}$ . Actual measurements with the above setup confirm this:

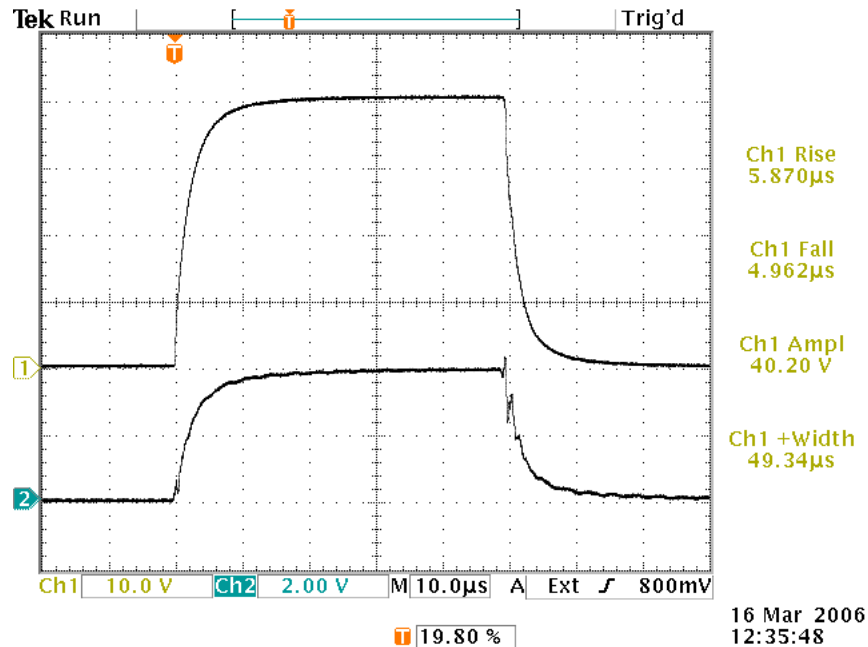

Top: Output at 0.2 Ohm load. ( $+40\text{V} / 0.2\Omega = +200\text{A}$ )

Bottom: Current monitor output.

10%-90% rise/fall measurements used.

The measured rise and fall times are approximately 5-6 us, as expected. (Compare this result to those obtained in the next section, using the DB-37 connector.)

### LOW-AVERAGE-POWER DB-37 CONNECTOR

The lower-average-power connector is a DB-37 female connector that will mate to Avtech AV-CLZ low impedance transmission lines (<http://www.avtechpulse.com/transmission/av-clz1>). This output is not rated for use above 75A of average current. However, the transmission line nature of the AV-CLZ cable and its low inductance ensure that the current rise time is not noticeably degraded by the cabling. The AV-CLZ cables must be ordered as an option (-AK6 option for a 60 cm cable), or they can be ordered as separate items. Longer cable lengths are available. See <http://www.avtechpulse.com/transmission/av-clz1> for model numbers.

Pins 1-19 (the bottom row) carry the output signal, and pins 20-37 (the top row) are the ground return.

An example setup using these connectors is shown in the photo below:

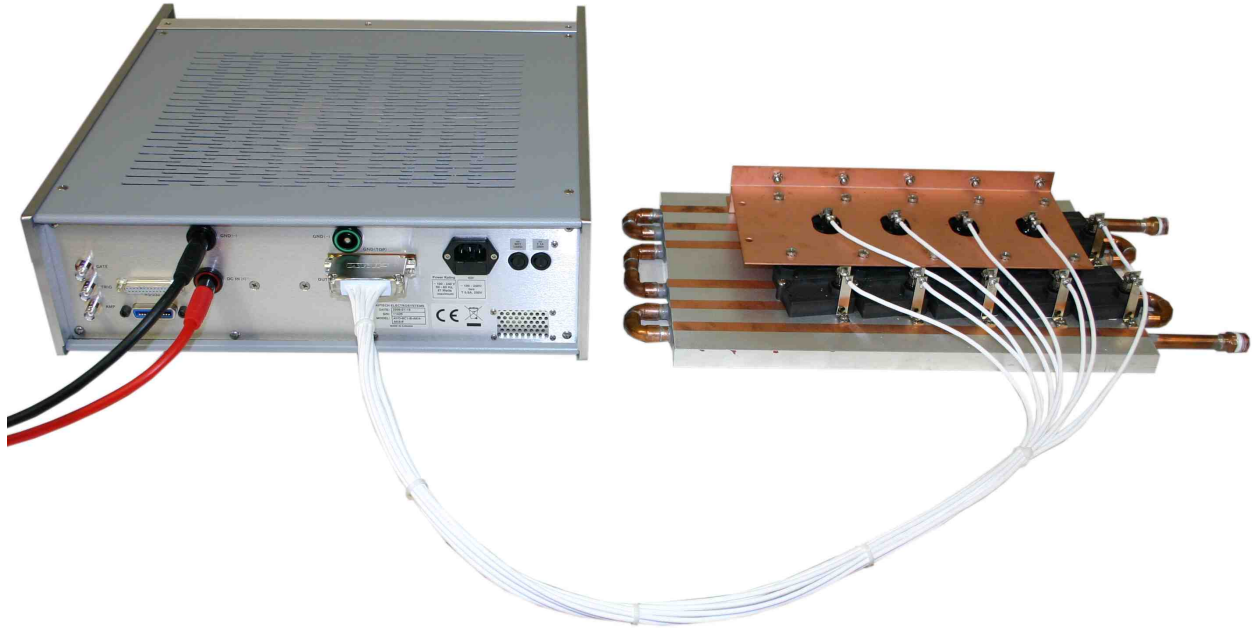

In the setup shown above, a high-power low-inductance Avtech AV-HTL-0R2 resistor is used as the load (<http://www.avtechpulse.com/accessories/av-htl-0r2>). This resistor has special low-inductance cabling (100 cm in length), and a resistance of 0.2 Ohms. Even though this length is twice as long as the cabling used in the 6 mm cable approach described earlier, the rise time is 6 times better:



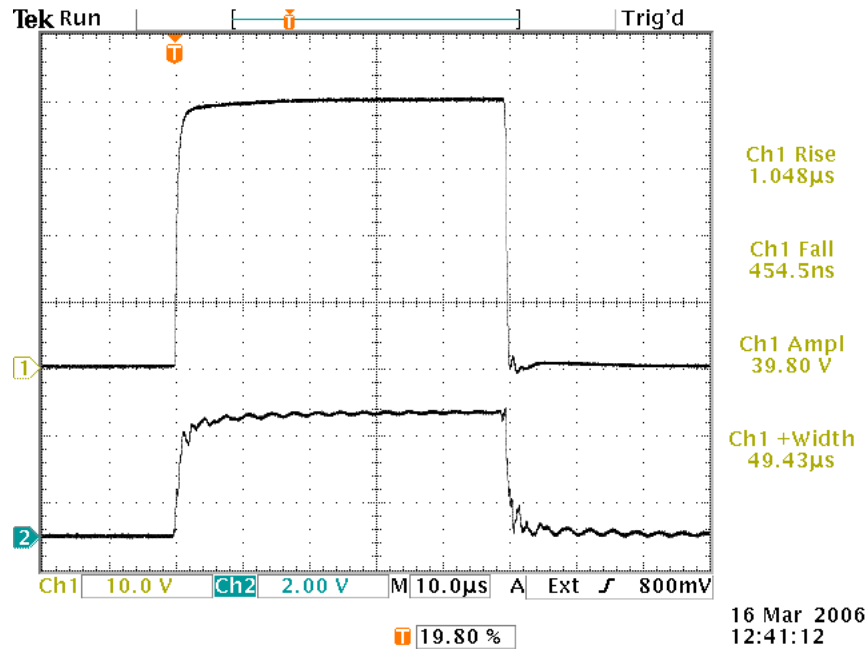

Top: Output at 0.2 Ohm load. ( $+40\text{V} / 0.2\Omega = +200\text{A}$ )  
 Bottom: Current monitor output.  
 10%-90% rise/fall measurements used.

The leading edge has a measured transition time of 1 us, compared to 6 us with the 6 mm cabling.

Certain factory tests are conducted using a smaller test load, consisting of five Ohmite AX10GK ceramic composition resistors (1 Ohm, 3.5W, 700 Joule) soldered in parallel on a DB-37 connector. This assembly is plugged into the end of an AV-CLZ1-60 cable, as shown below:

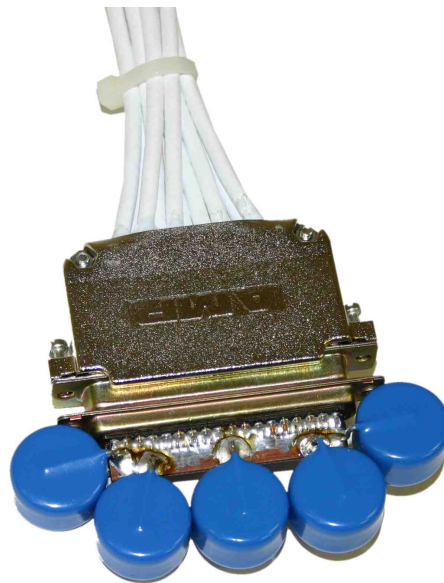

With this low-inductance load connected to the pulse using an AV-CLZ1-60, rise and fall times of < 1 us (on a 10%-90% basis) are obtained:

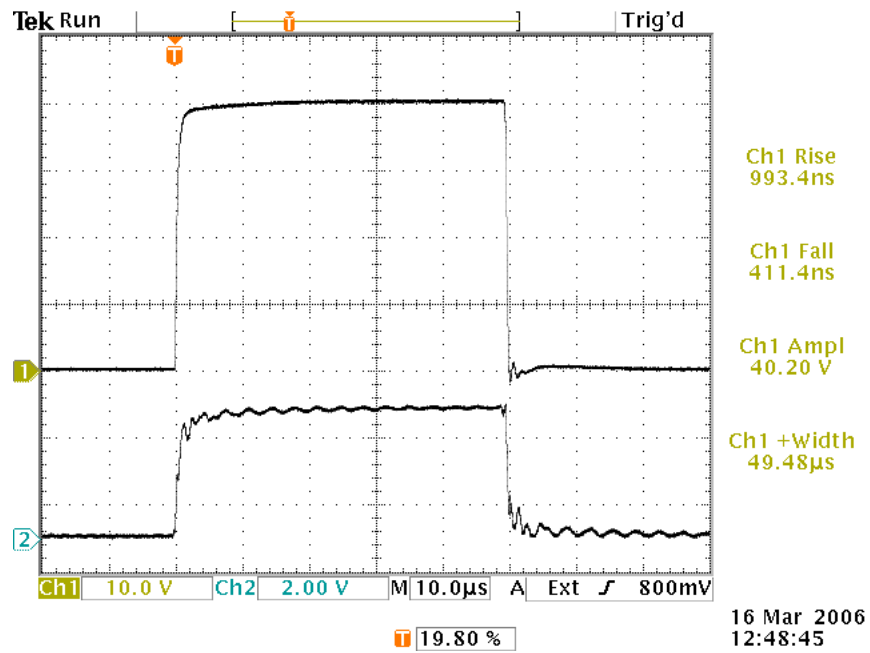

Top: Output at 0.2 Ohm load. ( $+40\text{V} / 0.2\Omega = +200\text{A}$ )  
Bottom: Current monitor output.  
10%-90% rise/fall measurements used.

## SELECTING AN APPROPRIATE SERIES RESISTANCE

The AVO-8C1-B-P is a voltage pulser. A resistance *must* be present in the load to limit the current to 200 Amps or lower.

If your load or device under test does not already have a current-limiting resistance, then additional resistance must be added in series with your device.

This resistance is typically 0.2 Ohms (i.e., 40V / 200A = 0.2  $\Omega$ ).

The power dissipated by the resistor may be as high as 4000W (depending on the voltage and duty cycle). It may be necessary to water-cool the resistor. The power dissipated in the resistor is given by

$$P = I^2 \times R \times PW / T,$$

where “I” is the current, “R” is the resistance, “PW” is the pulse width, and “T” is the pulse period (1/frequency).

It is very important to construct the series resistance so that the parasitic inductance is very low, otherwise the rise and fall times will be noticeably degraded. In general, wirewound resistors should be avoided due to their inductive design. Paralleling resistors is strongly recommended, since a parallel array of N resistors will reduce the overall parasitic inductance by a factor of N, compared to a single resistor.

For low average power applications (< 30 W), Avtech suggests using multiple Ohmite (<http://www.ohmite.com>) ceramic composition resistors in parallel. The Ohmite OX, OY, AW, AX, AY, and AZ series are all very rugged and low inductance.

For high average power applications, consider using the Ohmite TAP600 or TAP1000 heat-sinkable power resistors. The parasitic resistance associated with these resistors is on order of 80 nH. Several should be used in parallel, and be heatsunk on a water-cooled plate. (Suitable cooling plates are manufactured by D6 Industries, <http://www.d6industries.com>).

Avtech can construct high-power loads and series resistances for particular applications. Contact Avtech ([info@avtechpulse.com](mailto:info@avtechpulse.com)) with your requirement.

## CURRENT MONITOR

A current monitor output is provided on the rear panel of the instrument. The voltage waveform of the monitor output is proportional to the current waveform on the main output:

$$V_{\text{MON}} = I_{\text{OUT}} \times 1\text{V}/50\text{A}$$

for a load of  $> 1 \text{ k}\Omega$ . (The monitor output can also drive a  $50\Omega$  load, but the output voltage will be reduced by a factor of 2. This output is short-circuit protected.)

The current monitor circuit also measures the amplitude of the most recent pulse, in amperes, and displays it on the front panel LCD. The value can also be read via the computer interface.

The monitor loses accuracy for pulse widths of 10  $\mu\text{s}$  and less.

## ALARMS

The AVO-8C1-B-P has several protective circuits. An alarm circuit, with an audible buzzer, will sound and disable the output if:

- 1) The DC power supply voltage exceeds 45V.
- 2) The output circuitry overheats.
- 3) The maximum output current (100A in DC mode, 200A in other modes) is exceeded.

The buzzer may sound briefly when the power is first switched on. This is normal, and not a cause for concern.

### START-UP CHECK-LIST FOR LOCAL CONTROL

- 1) Read this manual thoroughly.
- 2) Read the “Local Control” section of the “Programming Manual for -B Instruments” thoroughly.
- 3) Connect the load to the output module. Note that with a diode load, a low-inductance current limiting high power resistor must be placed in series with the diode to help limit the peak current. For initial testing, it is recommended that a resistive load be used. Factory tests are conducted using a 0.2 Ohm 2000 Watt resistive load.
- 4) Connect the DC power supply to the instrument, as shown in the "Connecting to a Power Supply" section.
- 5) Turn on the prime power to the mainframe. The main menu will appear.
- 6) The arrow pointer should be pointing at the frequency menu item. If it is not, press the MOVE button until it is.
- 7) Press the CHANGE button. The frequency submenu will appear. Rotate the ADJUST knob until the frequency is set at the desired setting. The arrow pointer should be pointing at the “Internal” choice. If it is not, press MOVE until it is.
- 8) Press CHANGE to return to the main menu.
- 9) Press the MOVE button to move the arrow pointer to the pulse width menu item. Press CHANGE to bring up the pulse width submenu, and rotate the ADJUST knob until the pulse width is set at the desired setting. The arrow pointer should be pointing at the “Normal” choice. If it is not, press MOVE until it is. Press CHANGE to return to the main menu.
- 10) Press the MOVE button to move the arrow pointer to the pulse width menu item. Press CHANGE to bring up the pulse width submenu, and rotate the ADJUST knob until the pulse width is set at the desired setting. The arrow pointer should be pointing at the “Normal” choice. If it is not, press MOVE until it is. Press CHANGE to return to the main menu.
- 11) Press the MOVE button to move the arrow pointer is pointing at the output item. Press CHANGE to bring up the output submenu. The arrow pointer should be initially be pointing at the “Output Off” choice. Press MOVE so that the arrow pointer is pointing at the “Output On” choice. (The mainframe is now supplying a trigger to the output module.) Press CHANGE to return to the main menu.
- 12) Connect a scope probe across the resistive test load and apply prime power to the lab power supply (after first ensuring that the output amplitude is set to zero).

- 13) Gradually increase the output amplitude on the lab power supply and observe the waveforms on the scope and the DC current level on the DC power supply. A rectangular pulse should appear on the scope (for both the load voltage and monitor channels) and the amplitude should increase as the amplitude control on the mainframe is rotated clockwise. At the same time, the average current supplied by the DC supply will increase.
- 14) Observe the pulse width and pulse period on the scope and confirm that the peak current does not exceed 200 Amps.
- 15) Observe the DC current supplied by the DC supply and ensure that the average current does not exceed 100 Amperes.
- 16) Adjust pulse width, pulse period (i.e. PRF) and amplitude to obtain the desired settings.
- 17) If additional assistance is required:

Tel: (613) 226-5772, Fax: (613) 226-2802  
Email: [info@avtechpulse.com](mailto:info@avtechpulse.com)

## PROGRAMMING YOUR PULSE GENERATOR

### KEY PROGRAMMING COMMANDS

The “Programming Manual for -B Instruments” describes in detail how to connect the pulse generator to your computer, and the programming commands themselves. A large number of commands are available; however, normally you will only need a few of these. Here is a basic sample sequence of commands that might be sent to the instrument after power-up:

```
*rst                (resets the instrument)
trigger:source internal (selects internal triggering)
source:function pulse (enables pulse mode, rather than DC mode)
frequency 100 Hz    (sets the frequency to 100 Hz)
pulse:width 100 us  (sets the pulse width to 100 us)
pulse:delay 30 us   (sets the delay to 30 us)
output on           (turns on the output)
```

These commands will satisfy 90% of your programming needs.

### ALL PROGRAMMING COMMANDS

For more advanced programmers, a complete list of the available commands is given below. These commands are described in detail in the “Programming Manual for -B Instruments”. (Note: this manual also includes some commands that are not implemented in this instrument. They can be ignored.)

<u>Keyword</u>	<u>Parameter</u>	<u>Notes</u>
LOCAL		
OUTPut:		
:[STATE]	<boolean value>	
:PROTection		
:TRIPped?		[query only]
REMOTE		
[SOURce]:		
:FREQuency		
[:CW   FIXed]	<numeric value>	
[SOURce]:		
:FUNcTion		
:[SHAPE]	DC   PULSe	
[SOURce]:		
:PULSe		
:PERiod	<numeric value>	
:WIDTh	<numeric value>   IN	
:DCYCLE	<numeric value>	
:HOLD	WIDTh   DCYCLE	
:DELay	<numeric value>	
:GATE		

:TYPE	ASync   SYNC	
:LEVel	HIgh   LOw	
STATUS:		
:OPERation		
:[EVENT]?		[query only, always returns "0"]
:CONDition?		[query only, always returns "0"]
:ENABle	<numeric value>	[implemented but not useful]
:QUEStionable		
:[EVENT]?		[query only, always returns "0"]
:CONDition?		[query only, always returns "0"]
:ENABle	<numeric value>	[implemented but not useful]
SYSTem:		
:COMMunicate		
:GPIB		
:ADDRess	<numeric value>	
:SERial		
:CONTRol		
:RTS	ON   IBFull   RFR	
:[RECeive]		
:BAUD	1200   2400   4800   9600	
:BITS	7   8	
:ECHO	<boolean value>	
:PARity		
:[TYPE]	EVEN   ODD   NONE	
:SBITS	1   2	
:ERRor		
:[NEXT]?		[query only]
:COUNT?		[query only]
:VERsion?		[query only]
TRIGger:		
:SOURce	INTernal   EXTernal   MANual   HOLD   IMMEDIATE	
*CLS		[no query form]
*ESE	<numeric value>	
*ESR?		[query only]
*IDN?		[query only]
*OPC		
*SAV	0   1   2   3	[no query form]
*RCL	0   1   2   3	[no query form]
*RST		[no query form]
*SRE	<numeric value>	
*STB?		[query only]
*TST?		[query only]
*WAI		[no query form]



## MECHANICAL INFORMATION

### TOP COVER REMOVAL

If necessary, the interior of the instrument may be accessed by removing the four Phillips screws on the top panel. With the four screws removed, the top cover may be slid back (and off).

 Always disconnect the power cord and allow the instrument to sit unpowered for 10 minutes before opening the instrument. This will allow any internal stored charge to discharge.

There are no user-adjustable internal circuits. For repairs other than fuse replacement, please contact Avtech (info@avtechpulse.com) to arrange for the instrument to be returned to the factory for repair. Service is to be performed solely by qualified service personnel.

 Caution: High voltages are present inside the instrument during normal operation. Do not operate the instrument with the cover removed.

### RACK MOUNTING

A rack mounting kit is available. The -R6 rack mount kit may be installed after first removing the one Phillips screw on the side panel adjacent to the front handle.

### ELECTROMAGNETIC INTERFERENCE

To prevent electromagnetic interference with other equipment, all used outputs should be connected to shielded loads using shielded coaxial cables. Unused outputs should be terminated with shielded coaxial terminators or with shielded coaxial dust caps, to prevent unintentional electromagnetic radiation. All cords and cables should be less than 3m in length.

## MAINTENANCE

### REGULAR MAINTENANCE

This instrument does not require any regular maintenance.

On occasion, one or more of the four rear-panel fuses may require replacement. All fuses can be accessed from the rear panel. See the “FUSES” section for details.

### CLEANING

If desired, the interior of the instrument may be cleaned using compressed air to dislodge any accumulated dust. (See the “TOP COVER REMOVAL” section for instructions on accessing the interior.) No other cleaning is recommended.

# WIRING DIAGRAMS

## WIRING OF AC POWER

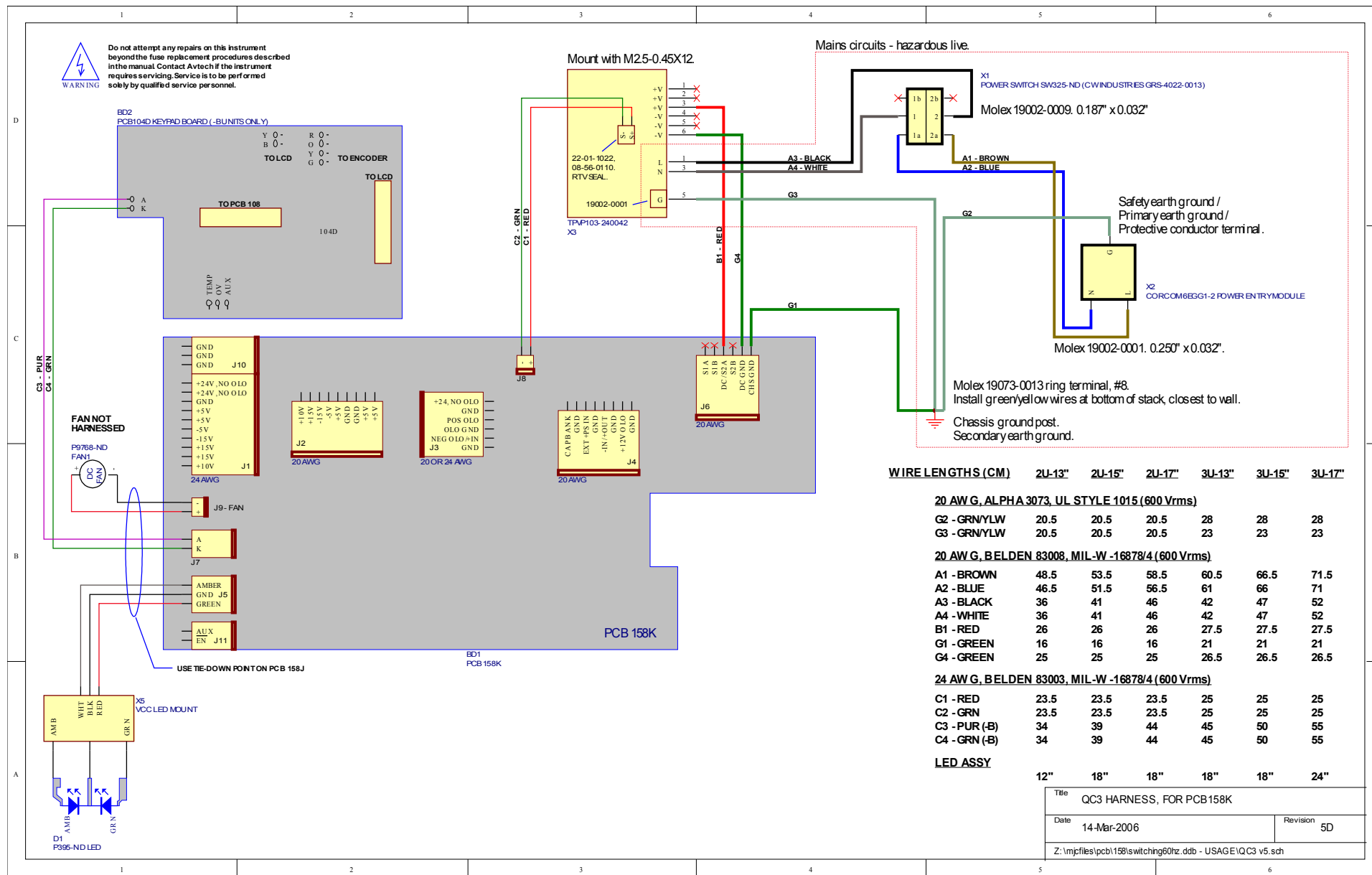

# PCB 158K - LOW VOLTAGE POWER SUPPLY, 1/3

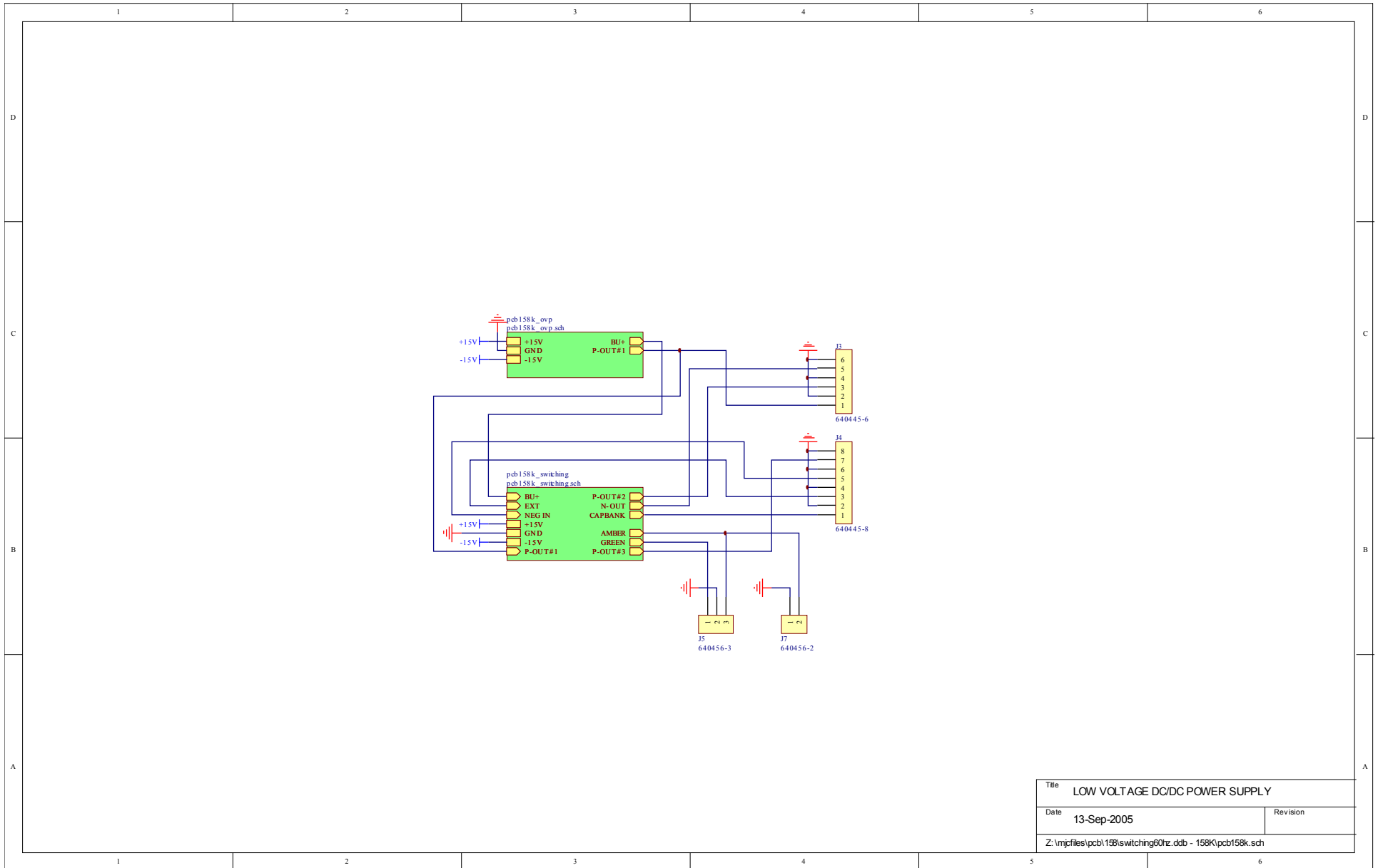

Title		LOW VOLTAGE DC/DC POWER SUPPLY
Date	13-Sep-2005	Revision
Z:\mpfiles\pcb158\switching60hz.ddb - 158K\pcb158k.sch		

# PCB 158K - LOW VOLTAGE POWER SUPPLY, 2/3

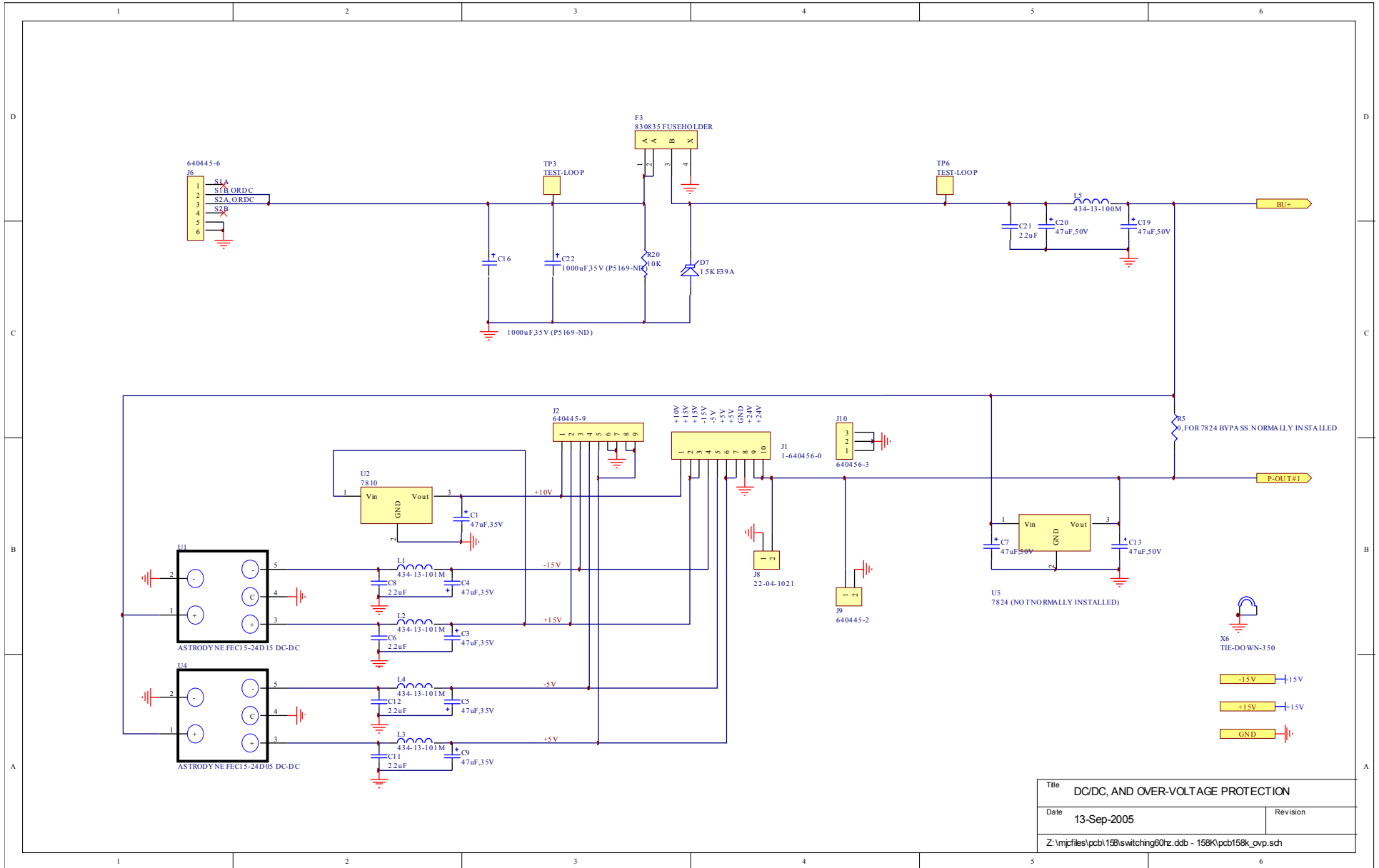

# PCB 158K - LOW VOLTAGE POWER SUPPLY, 3/3

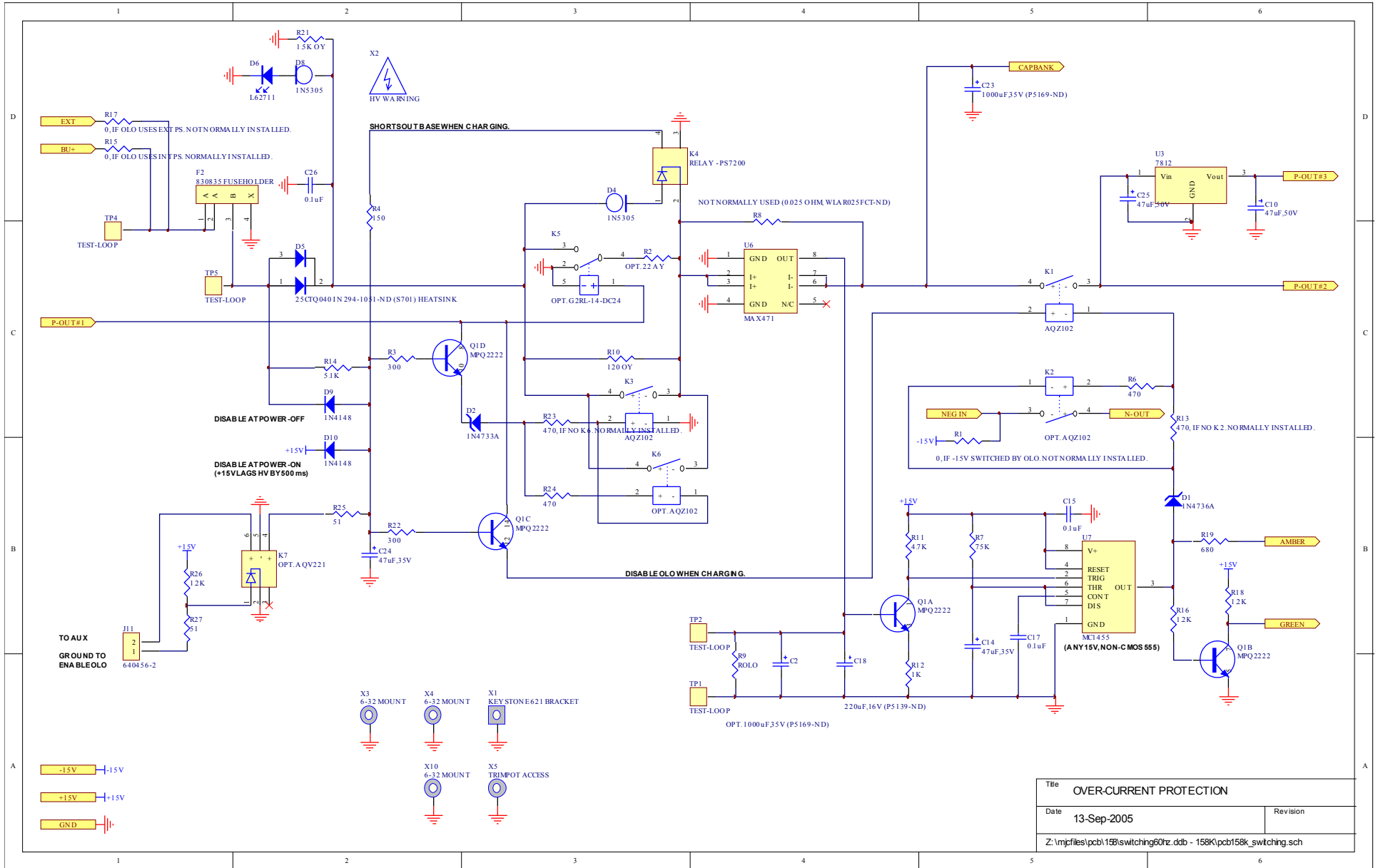

# PCB 104D - KEYPAD / DISPLAY BOARD, 1/3

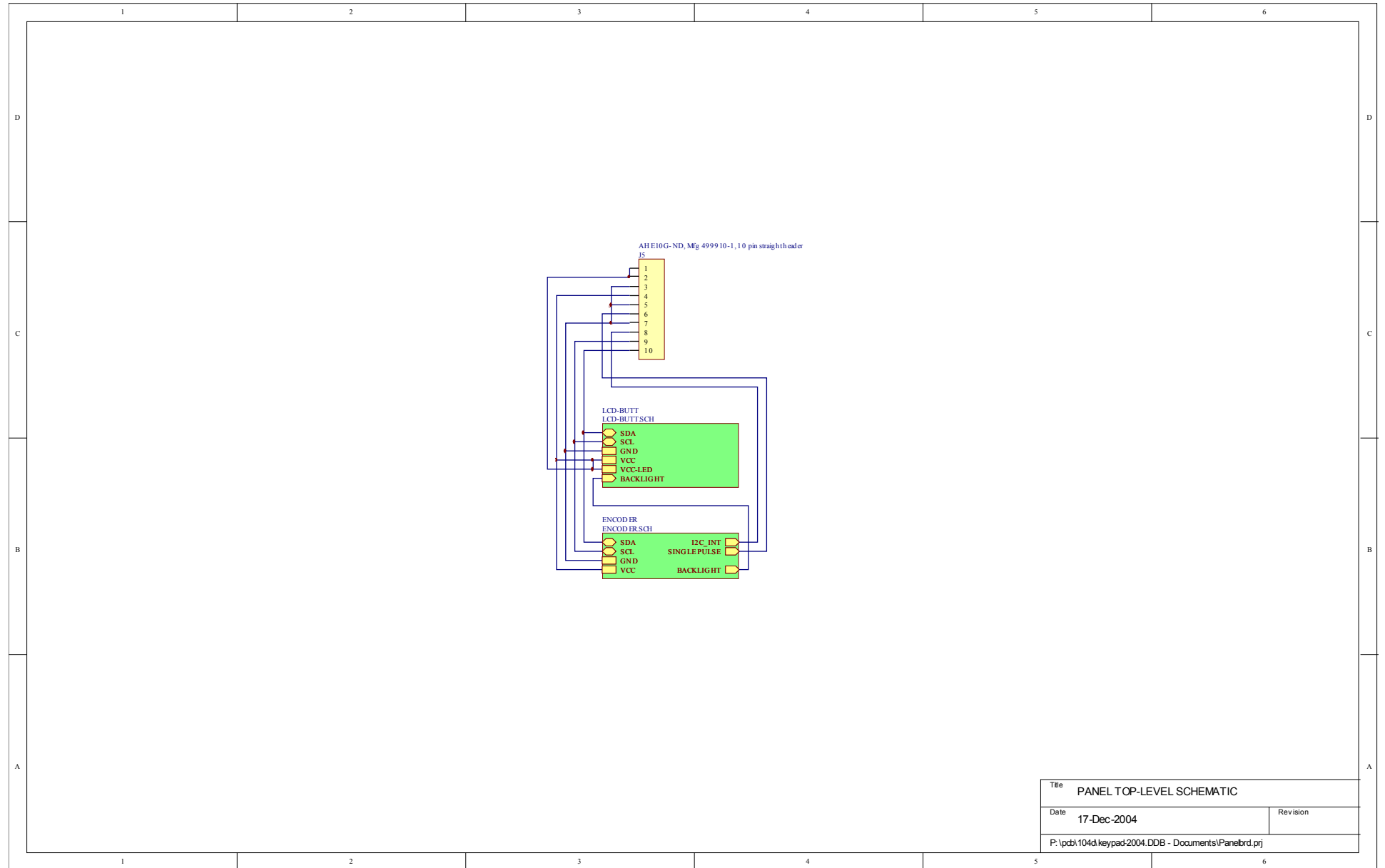

Title		PANEL TOP-LEVEL SCHEMATIC	
Date	17-Dec-2004	Revision	
P:\pcb\104d\keypad-2004.DDB - Documents\Panelbrd.prj			

# PCB 104D - KEYPAD / DISPLAY BOARD, 2/3

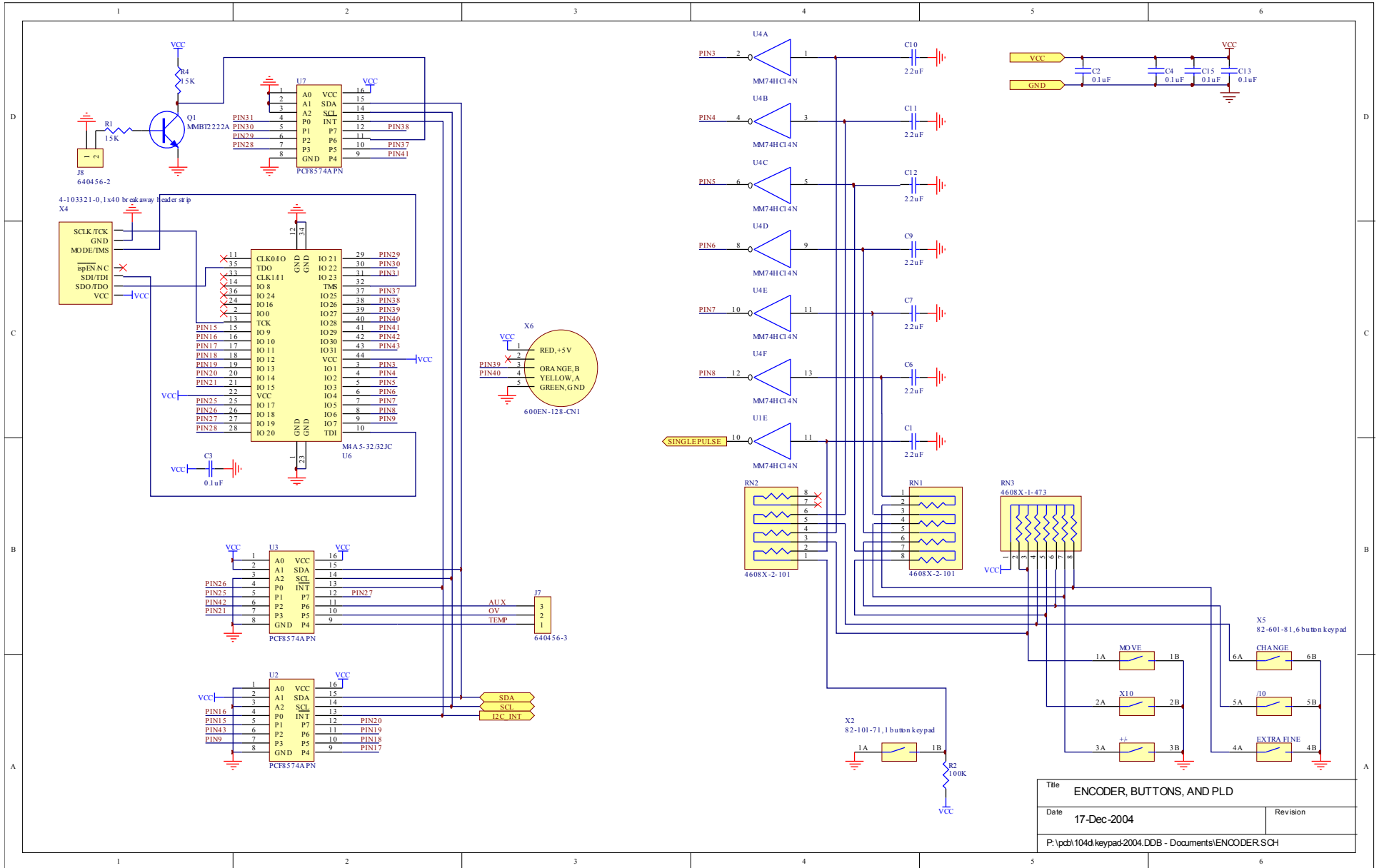

Title		ENCODER, BUTTONS, AND PLD
Date	17-Dec-2004	Revision
P:\pcb\104d\keypad\2004.DDB - Documents\ENCODER.SCH		



# PCB 104D - KEYPAD / DISPLAY BOARD, 3/3

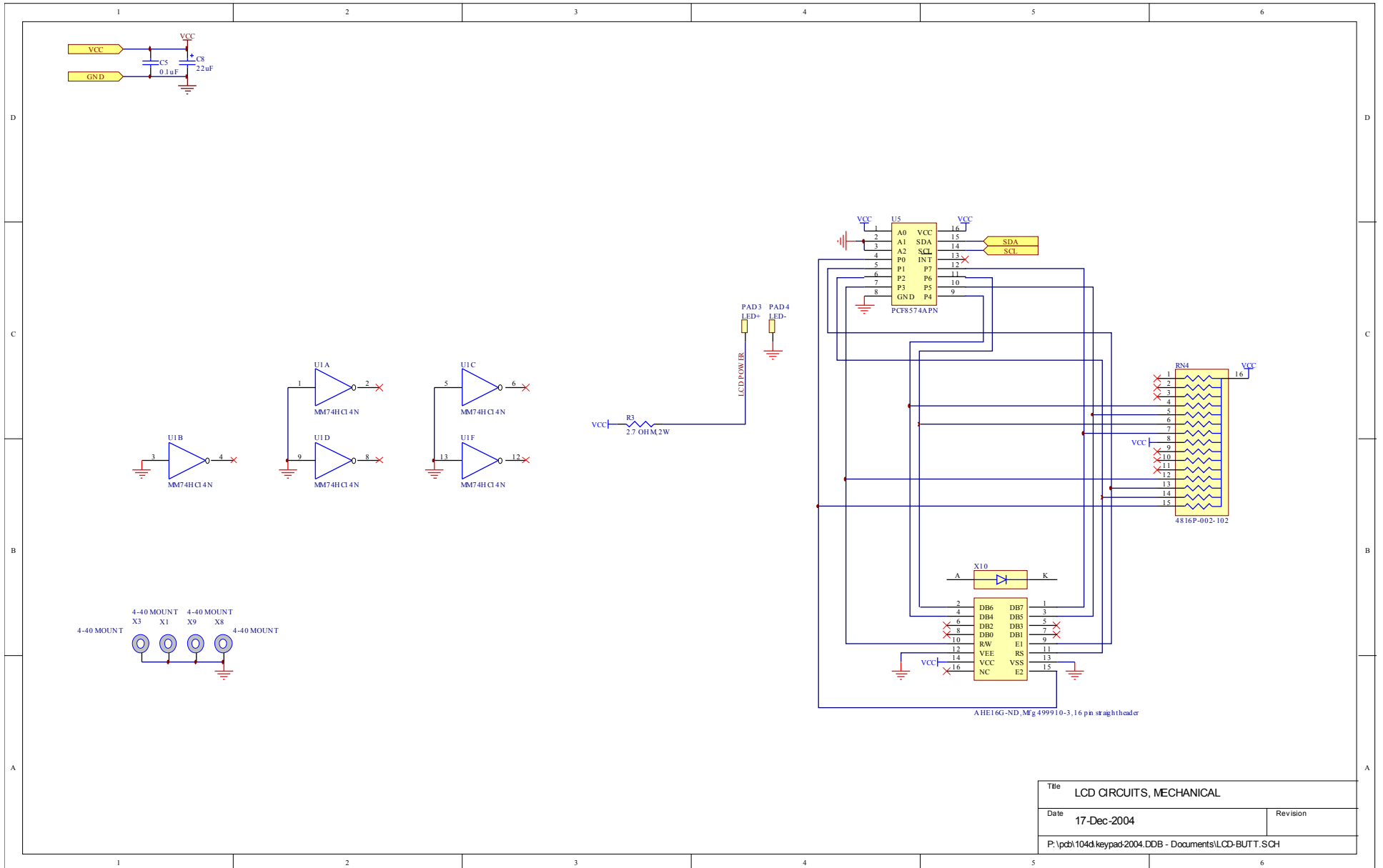

# PCB 116B - CURRENT MONITOR

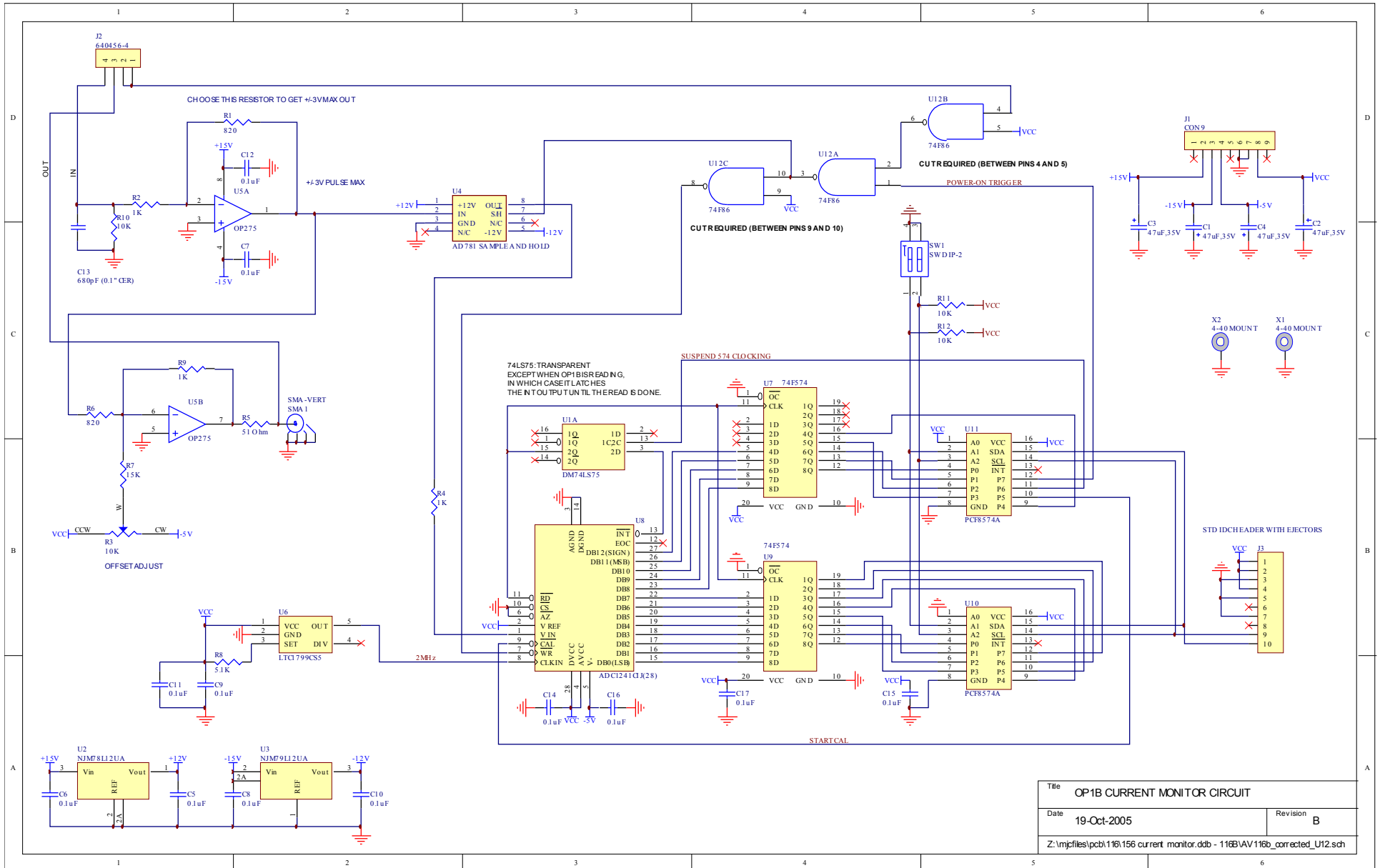

Title		OP1B CURRENT MONITOR CIRCUIT	
Date	19-Oct-2005	Revision	B
Z:\mjcfiles\pcb\116\156 current_monitor.ddb - 116B\AV\116b_corrected_U12.sch			

# PCB 94E - ALARM BOARD

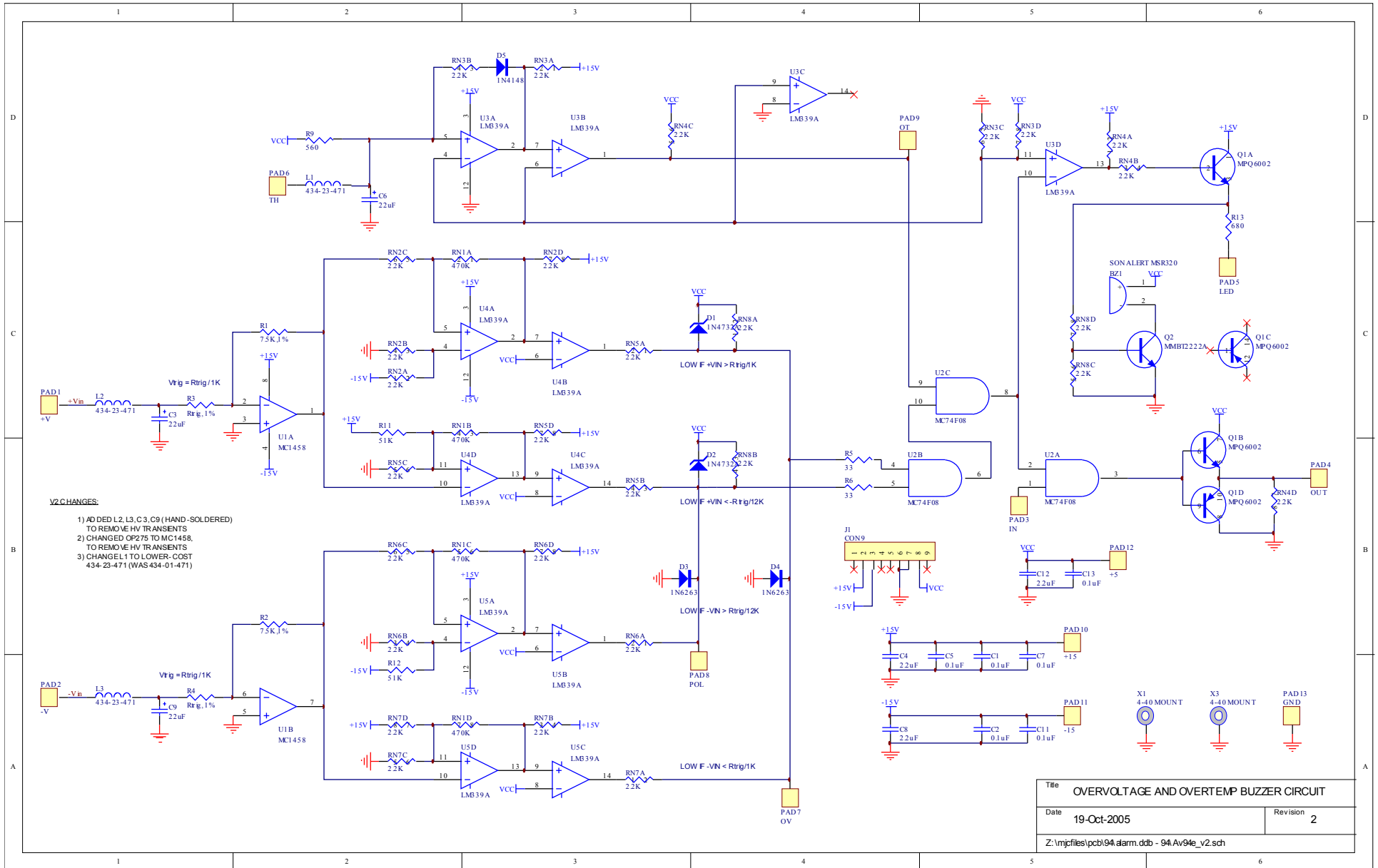

# PCB 186B - DRIVER

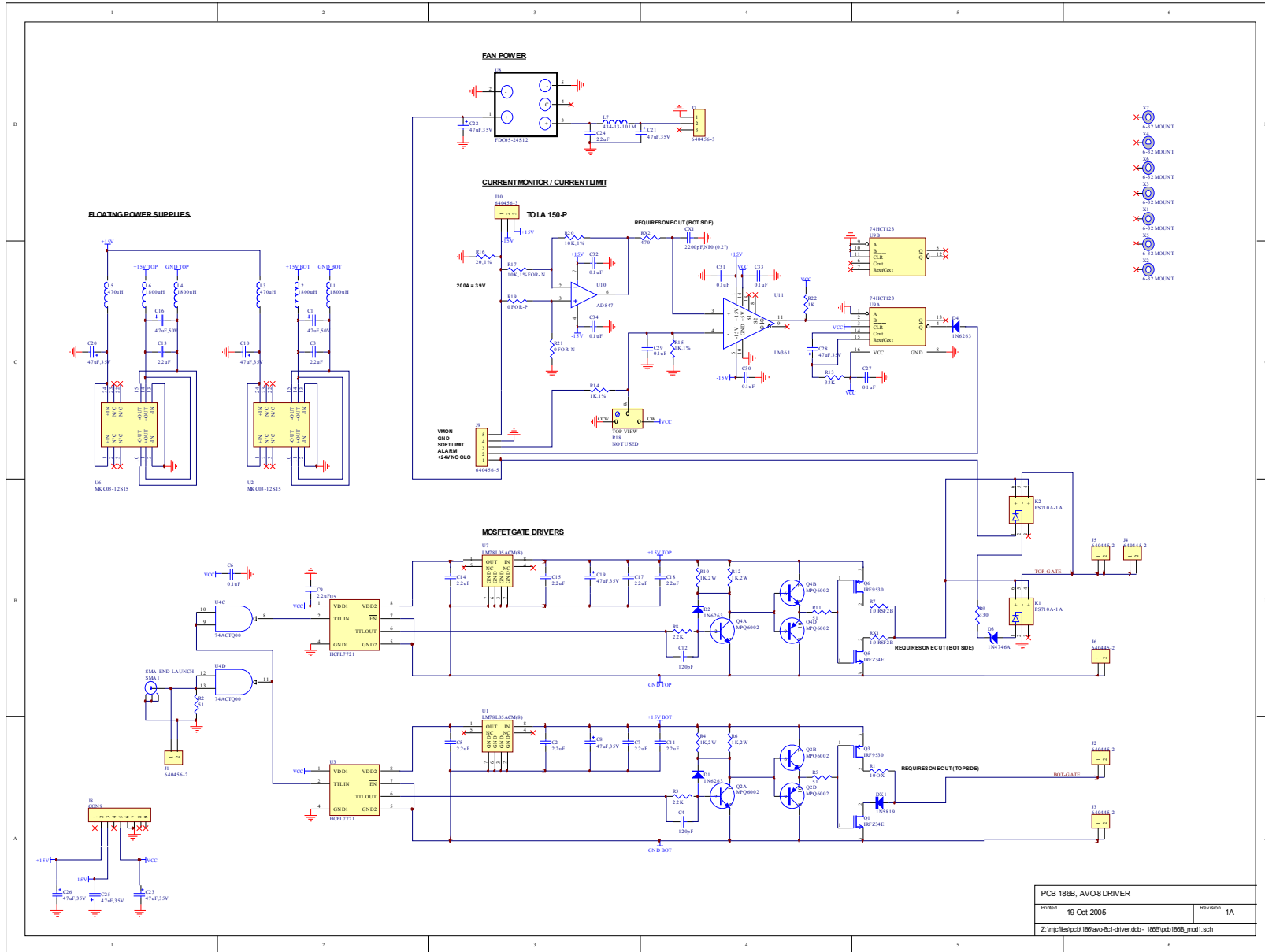

PCB 186B, AV08 DRIVER		
Printed	19-Oct-2005	Revision 1A
Z:\wpf\res\pcb\186-avo-8c1-driver.ddb - 186B\pcb186B_mod1.sch		

# MAIN WIRING - POSITIVE UNITS (-P)

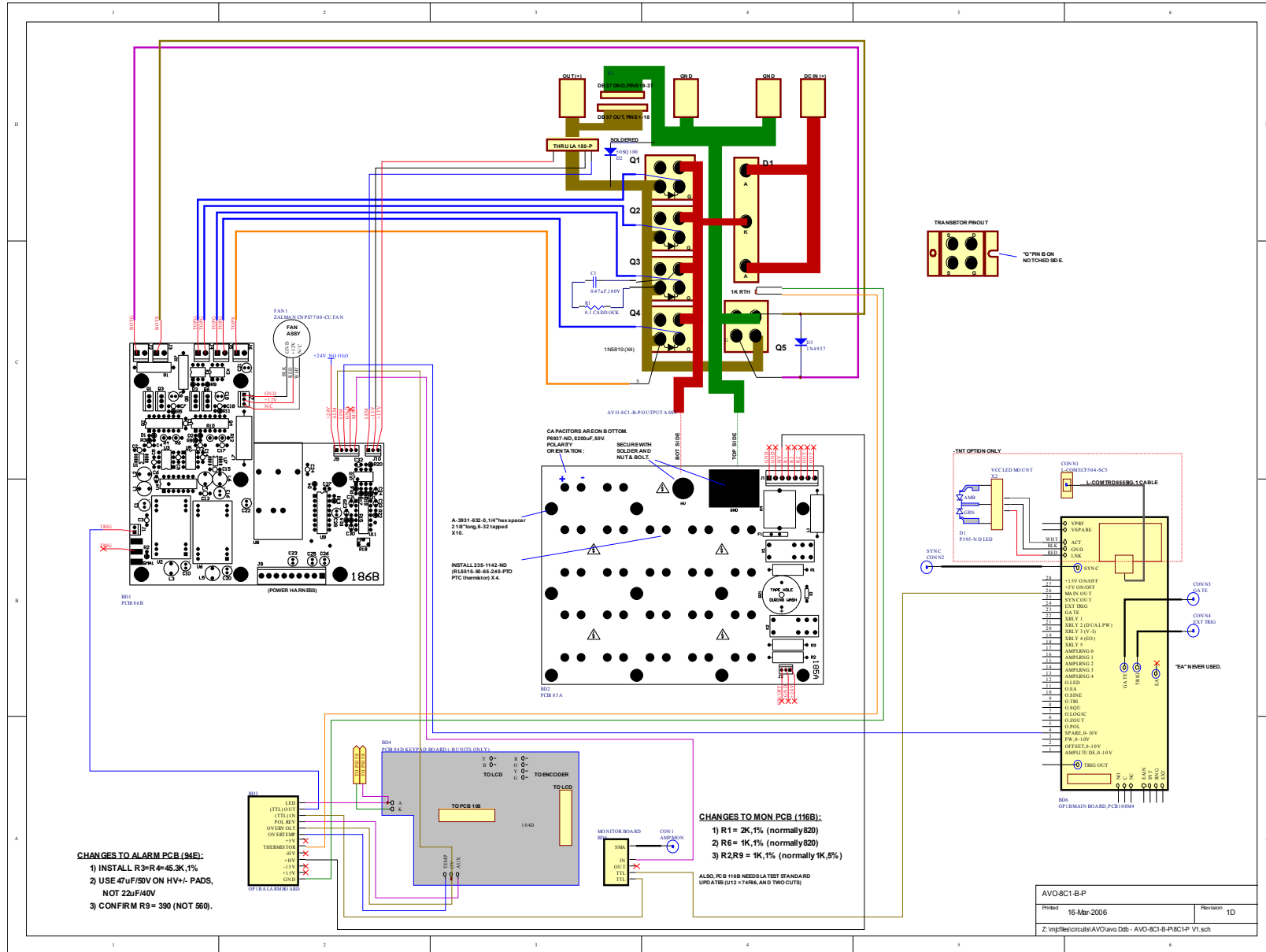

## APPENDIX A - DC POWER SUPPLIES

For your convenience, several DC supplies that may be appropriate for use with the AVO-8C1-B-P are listed below. Please consult the manufacturer data sheets for the latest, most accurate information.

Manufacturer	Model	AC Power	Maximum Output	Maximum Duty Cycle at 200A	Remote Control
Xantrex, www.xantrex.com	XHR 40-25	1 $\phi$ , 120/240V	40V, 25A	12.5%	Analog, GPIB optional
	XFR 40-70	3 $\phi$ , 120/240V	40V, 70A	35%	Analog, GPIB optional
	XDC 40-300	3 $\phi$ , 240V	40V, 300A	100%	Analog, GPIB optional
Sorensen, www.sorensen.com	DCR 40-40B2	1 $\phi$ , 120V	40V, 40A	20%	Analog
	DCR 40-70B2	1 $\phi$ , 240V	40V, 70A	35%	Analog
	DHP 40-250	3 $\phi$ , 240V	40V, 250A	100%	Analog, GPIB optional
Kepeco, www.kepeco.com	JQE 55-20M	1 $\phi$ , 120/240V	55V, 20A	10%	Analog
Agilent, www.agilent.com	6012B	1 $\phi$ , 120/240V	40V, 30A*	15%	Analog
	6032A	1 $\phi$ , 120/240V	40V, 30A*	15%	Analog, GPIB standard
	6684A	3 $\phi$ , 220V	40V, 128A	64%	Analog, GPIB standard

\* can generate higher voltages or higher currents, but not simultaneously.

PERFORMANCE CHECK SHEET